

Series 92

Clear, unambiguous and intuitive.

<https://eao.com/>



92 Information about the Series

Key advantages

- Mounted on PCBs
- Intuitive to use
- Bright illumination

Typical application areas

- Audio / video
- Measurement technology
- Medical engineering

Functions

- Pushbutton
- Illuminated pushbutton
- Indicator

Design

- Raised

IP front protection

- IP40
- IP67

Raitings

- 42 VAC (100 mA)

Mounting cut-outs

- Ø 16 mm

Terminal

- PCB

Lens Material

- Plastic

Markings

- Engraving
- Laser marking
- Hot stamping

Approvals

- CQC

Conformities

- CE
- UKCA
- 2014/35/EU (LVD)
- 2011/65/EU (RoHS)



PCB	
Pushbutton	950
Pushbutton	952
Pushbutton	953
Illuminated pushbutton	954
Illuminated pushbutton	956
Illuminated pushbutton	957
Indicator	958
Indicator	959
Components	960
Accessories	965
Technical data	967
Marking	968
Application guidelines	969

- 01
- 02
- 03
- 04
- 09
- 14
- 17
- 18
- 19
- 22
- 31
- 41
- 45
- 51
- 56
- 57
- 61
- 70
- 71
- 82
- 84
- 92**
- 96

Pushbutton



Product can differ from the current configuration.

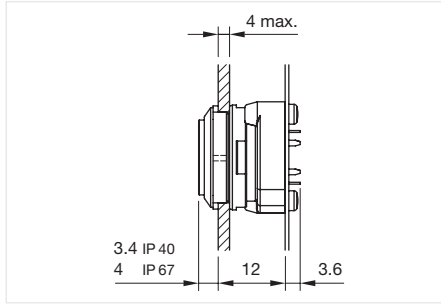

Dimensions [mm]

General information

- Lens opaque

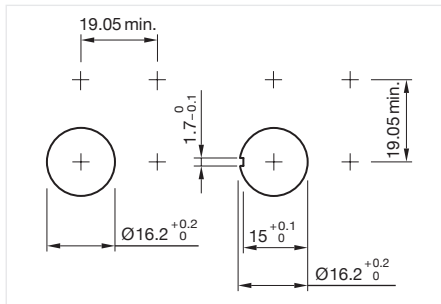

Mounting cut-outs [mm]

Equipment consisting of (schematic overview)

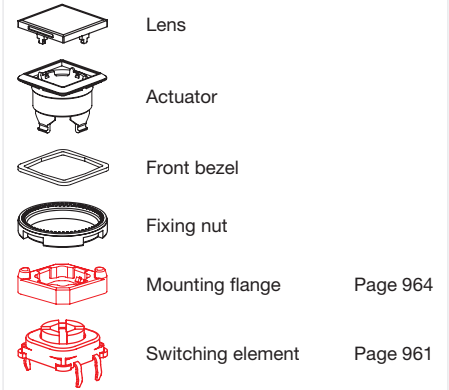

Each Part Number listed below includes all the black components shown in the 3D-drawing.

To obtain a complete unit, please select the red components from the pages shown.



Actuator

Front bezel colour	Front bezel material	Switching action	IP front protection	Lens colour	Lens material	Housing colour	Housing material	Dimensions	Part No.	Wiring diagram
Black	Plastic	Momentary	IP67	Black	Plastic	White	Plastic	18.8 mm x 18.8 mm	92-441.000	72
	Plastic	Momentary	IP67	Grey	Plastic	White	Plastic	18.8 mm x 18.8 mm	92-441.800	72



Actuator

Front bezel colour	Front bezel material	Switching action	IP front protection	Lens colour	Lens material	Housing colour	Housing material	Dimensions	Part No.	Wiring diagram
White	Plastic	Momentary	IP40	Black	Plastic	White	Plastic	18.4 mm x 18.4 mm	92-356.000	72
	Plastic	Momentary	IP40	Grey	Plastic	White	Plastic	18.4 mm x 18.4 mm	92-356.800	72
Black	Plastic	Momentary	IP40	Grey	Plastic	White	Plastic	18.4 mm x 18.4 mm	92-456.800	72
	Plastic	Momentary	IP40	White	Plastic	White	Plastic	18.4 mm x 18.4 mm	92-456.900	72
	Plastic	Momentary	IP40	Red	Plastic	White	Plastic	18.4 mm x 18.4 mm	92-456.200	72
	Plastic	Momentary	IP40	Green	Plastic	White	Plastic	18.4 mm x 18.4 mm	92-456.500	72

Wiring diagrams

E---

Wiring diagram 72

01
02
03
04
09
14
17
18
19
22
31
41
45
51
56
57
61
70
71
82
84
92
96



EAO Downloads.
www.eao.com/downloads
EAO creates possibilities. Since 1947.



[On our website you can download technical data, assembly instructions, catalogs, brochures and much more.](http://www.eao.com/downloads)

Pushbutton



Product can differ from the current configuration.

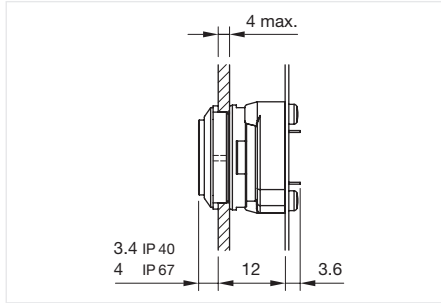

Dimensions [mm]

General information

- Lens opaque

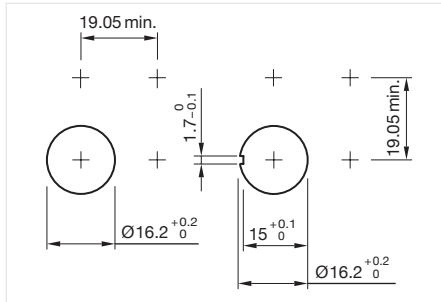

Mounting cut-outs [mm]

Equipment consisting of (schematic overview)

	Lens	Page 960
	Actuator	
	Front bezel	Page 960
	Fixing nut	
	Mounting flange	Page 964
	Switching element	Page 961

Each Part Number listed below includes all the black components shown in the 3D-drawing.

To obtain a complete unit, please select the red components from the pages shown.

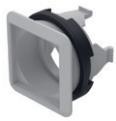

Actuator





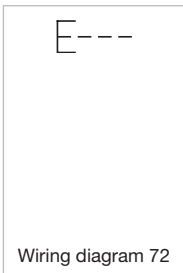

Front bezel colour	Front bezel material	Switching action	IP front protection	Housing colour	Housing material	Part No.	Wiring diagram
White	Plastic	Momentary	IP40	White	Plastic	92-350.000	72
Black	Plastic	Momentary	IP40	White	Plastic	92-450.000	72

Wiring diagrams



Pushbutton

Equipment consisting of (schematic overview)

-  Lens Page 960
-  Front bezel
-  Actuator
-  Fixing nut
-  Mounting flange Page 964
-  Switching element Page 961

Each Part Number listed below includes all the black components shown in the 3D-drawing.

To obtain a complete unit, please select the red components from the pages shown.

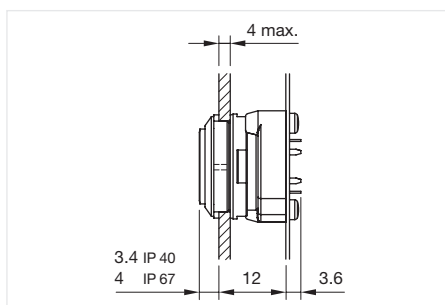

Dimensions [mm]



Product can differ from the current configuration.

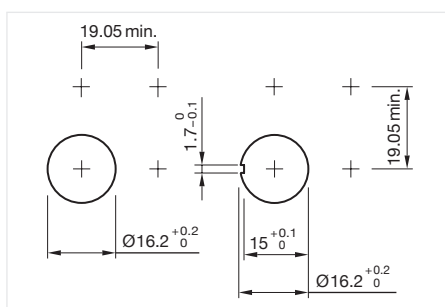

Mounting cut-outs [mm]

General information

- Lens opaque



Actuator, Front dimension 18,8 mm x 18,8 mm

Front bezel colour	Front bezel material	Switching action	IP front protection	Housing colour	Housing material	Part No.	Wiring diagram
White	Plastic	Momentary	IP67	White	Plastic	92-340.000	72
Black	Plastic	Momentary	IP67	White	Plastic	92-440.000	72

Wiring diagrams

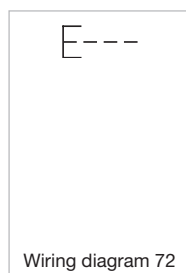

01
02
03
04
09
14
17
18
19
22
31
41
45
51
56
57
61
70
71
82
84
92
96

Illuminated pushbutton



Product can differ from the current configuration.

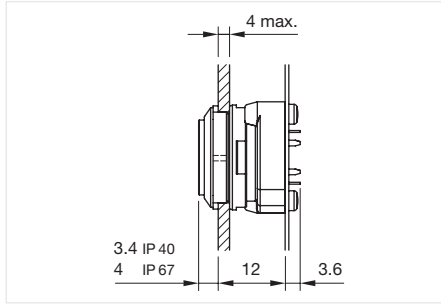

General information

- Transparent lens and pressure plate

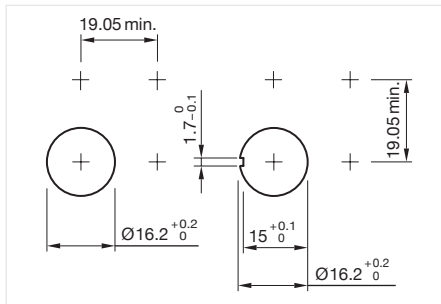

Equipment consisting of (schematic overview)

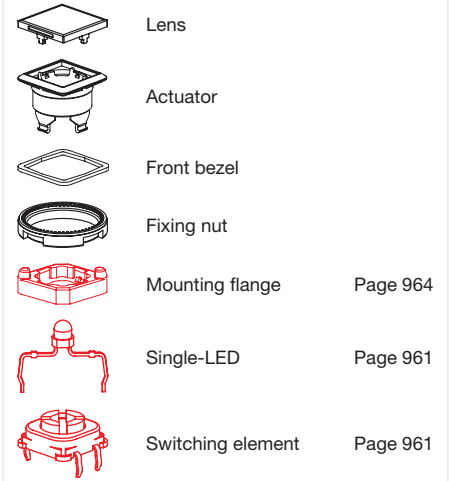

Each Part Number listed below includes all the black components shown in the 3D-drawing.

To obtain a complete unit, please select the red components from the pages shown.

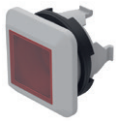

Actuator

Front bezel colour	Front bezel material	Switching action	IP front protection	Lens colour	Lens material	Housing colour	Housing material	Dimensions	Part No.	Wiring diagram
White	Plastic	Momentary	IP67	Orange	Plastic	White	Plastic	18.8 mm x 18.8 mm	92-343.300	357
	Plastic	Momentary	IP67	Yellow	Plastic	White	Plastic	18.8 mm x 18.8 mm	92-343.400	357
	Plastic	Momentary	IP67	Colour-less	Plastic	White	Plastic	18.8 mm x 18.8 mm	92-343.700	357
	Plastic	Momentary	IP40	Red	Plastic	White	Plastic	18.4 mm x 18.4 mm	92-358.200	357
	Plastic	Momentary	IP40	Yellow	Plastic	White	Plastic	18.4 mm x 18.4 mm	92-358.400	357
	Plastic	Momentary	IP40	Green	Plastic	White	Plastic	18.4 mm x 18.4 mm	92-358.500	357
	Plastic	Momentary	IP40	Blue	Plastic	White	Plastic	18.4 mm x 18.4 mm	92-358.600	357
	Plastic	Momentary	IP40	Colour-less	Plastic	White	Plastic	18.4 mm x 18.4 mm	92-358.700	357
Black	Plastic	Momentary	IP67	Red	Plastic	White	Plastic	18.8 mm x 18.8 mm	92-443.200	357
	Plastic	Momentary	IP67	Orange	Plastic	White	Plastic	18.8 mm x 18.8 mm	92-443.300	357
	Plastic	Momentary	IP67	Yellow	Plastic	White	Plastic	18.8 mm x 18.8 mm	92-443.400	357
	Plastic	Momentary	IP67	Green	Plastic	White	Plastic	18.8 mm x 18.8 mm	92-443.500	357
	Plastic	Momentary	IP67	Blue	Plastic	White	Plastic	18.8 mm x 18.8 mm	92-443.600	357
	Plastic	Momentary	IP67	Colour-less	Plastic	White	Plastic	18.8 mm x 18.8 mm	92-443.700	357



Actuator

Front bezel colour	Front bezel material	Switching action	IP front protection	Lens colour	Lens material	Housing colour	Housing material	Dimensions	Part No.	Wiring diagram
Black	Plastic	Momentary	IP40	Smokey black	Plastic	White	Plastic	18.4 mm x 18.4 mm	92-458.100	357
	Plastic	Momentary	IP40	Red	Plastic	White	Plastic	18.4 mm x 18.4 mm	92-458.200	357
	Plastic	Momentary	IP40	Orange	Plastic	White	Plastic	18.4 mm x 18.4 mm	92-458.300	357
	Plastic	Momentary	IP40	Yellow	Plastic	White	Plastic	18.4 mm x 18.4 mm	92-458.400	357
	Plastic	Momentary	IP40	Green	Plastic	White	Plastic	18.4 mm x 18.4 mm	92-458.500	357
	Plastic	Momentary	IP40	Blue	Plastic	White	Plastic	18.4 mm x 18.4 mm	92-458.600	357
	Plastic	Momentary	IP40	Colourless	Plastic	White	Plastic	18.4 mm x 18.4 mm	92-458.700	357

Wiring diagrams

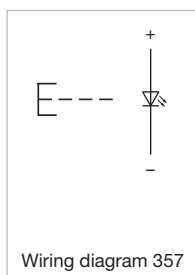

- 01
- 02
- 03
- 04
- 09
- 14
- 17
- 18
- 19
- 22
- 31
- 41
- 45
- 51
- 56
- 57
- 61
- 70
- 71
- 82
- 84
- 92**
- 96

Illuminated pushbutton

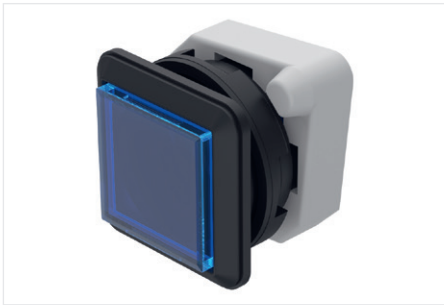

Product can differ from the current configuration.

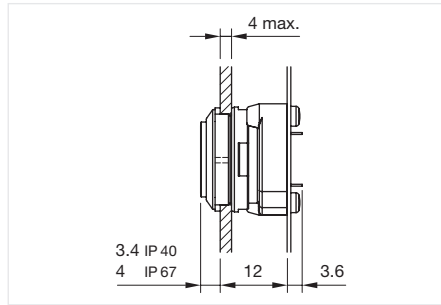

Dimensions [mm]

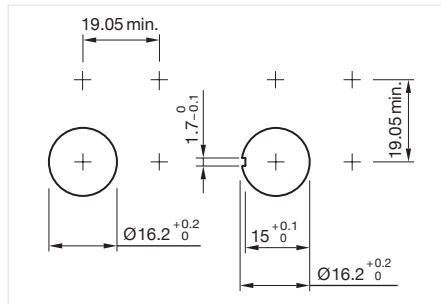

Mounting cut-outs [mm]

Equipment consisting of (schematic overview)

	Lens	Page 960
	Actuator	
	Front bezel	Page 960
	Fixing nut	
	Mounting flange	Page 964
	Single-LED	Page 961
	Switching element	Page 961

Each Part Number listed below includes all the black components shown in the 3D-drawing.

To obtain a complete unit, please select the red components from the pages shown.

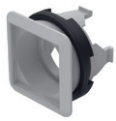

Actuator, Front dimension 18,4 mm x 18,4 mm





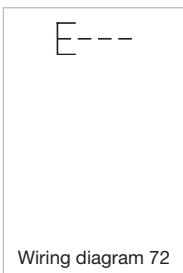

Front bezel colour	Front bezel material	Switching action	IP front protection	Housing colour	Housing material	Part No.	Wiring diagram
White	Plastic	Momentary	IP40	White	Plastic	92-350.000	72
Black	Plastic	Momentary	IP40	White	Plastic	92-450.000	72

Wiring diagrams



Illuminated pushbutton

Equipment consisting of (schematic overview)

-  Pressure plate Page 960
-  Front bezel
-  Actuator
-  Fixing nut
-  Mounting flange Page 964
-  Single-LED Page 961
-  Switching element Page 961

Each Part Number listed below includes all the black components shown in the 3D-drawing.

To obtain a complete unit, please select the red components from the pages shown.

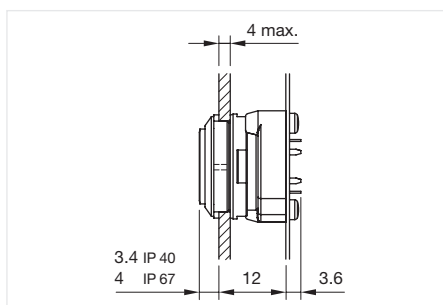

Dimensions [mm]



Product can differ from the current configuration.

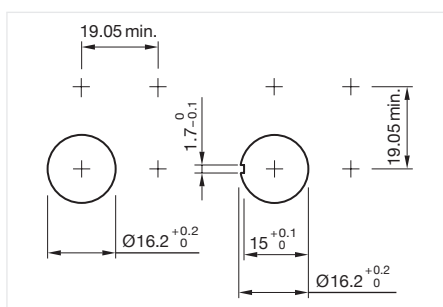

Mounting cut-outs [mm]



Actuator, Front dimension 18,8 mm x 18,8 mm

Front bezel colour	Front bezel material	Switching action	IP front protection	Housing colour	Housing material	Part No.	Wiring diagram
White	Plastic	Momentary	IP67	White	Plastic	92-340.000	72
Black	Plastic	Momentary	IP67	White	Plastic	92-440.000	72

Wiring diagrams

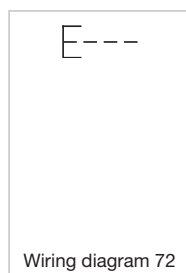

Indicator



Product can differ from the current configuration.

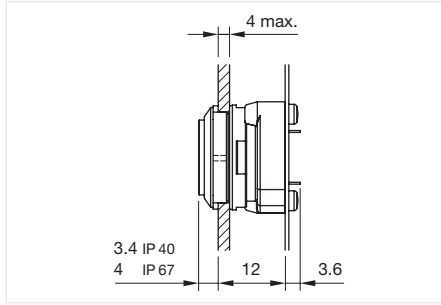

Dimensions [mm]

General information

- Transparent lens and pressure plate

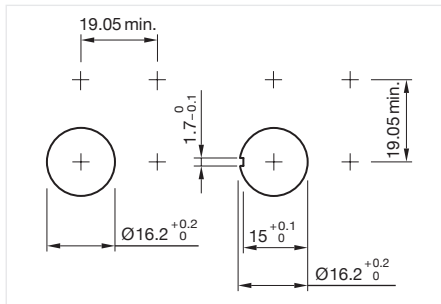

Mounting cut-outs [mm]

Equipment consisting of (schematic overview)

	Lens	
	Actuator	
	Front bezel	
	Fixing nut	
	Mounting flange	Page 964
	Single-LED	Page 961
	Illumination element	Page 962

Each Part Number listed below includes all the black components shown in the 3D-drawing.

To obtain a complete unit, please select the red components from the pages shown.



Actuator





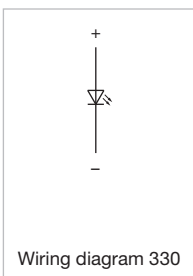

Front bezel colour	Front bezel material	IP front protection	Lens colour	Lens material	Lens plate colour	Lens plate material	Dimensions	Part No.	Wiring diagram
Black	Plastic	IP67		Plastic	Red	Plastic	18.8 mm x 18.8 mm	92-143.200	330
	Plastic	IP67		Plastic	Yellow	Plastic	18.8 mm x 18.8 mm	92-143.400	330
	Plastic	IP67		Plastic	Green	Plastic	18.8 mm x 18.8 mm	92-143.500	330
	Plastic	IP40	Green	Plastic			18.4 mm x 18.4 mm	92-158.500	330
	Plastic	IP40	Colourless	Plastic			18.4 mm x 18.4 mm	92-158.700	330

Wiring diagrams



Indicator, IP67

Equipment consisting of (schematic overview)

-  Pressure plate Page 960
-  Front bezel
-  Actuator
-  Fixing nut
-  Mounting flange Page 964
-  Single-LED Page 961
-  Illumination element Page 962

Each Part Number listed below includes all the black components shown in the 3D-drawing.

To obtain a complete unit, please select the red components from the pages shown.

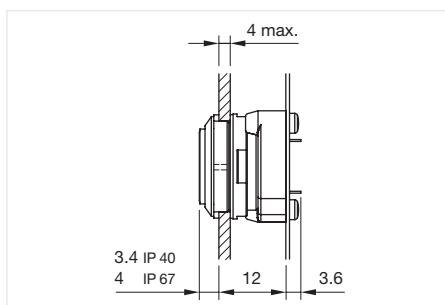

Dimensions [mm]



Product can differ from the current configuration.

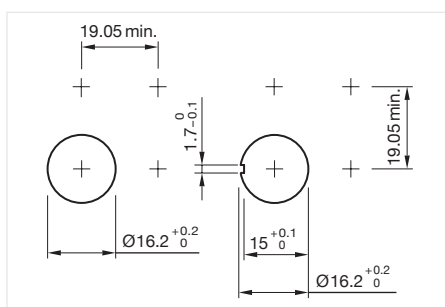

Mounting cut-outs [mm]

General information

- Transparent lens and pressure plate



Actuator, Front dimension 18,8 mm x 18,8 mm

Front bezel colour	Front bezel material	IP front protection	Part No.	Wiring diagram
Black	Plastic	IP67	92-140.000	330

Wiring diagrams

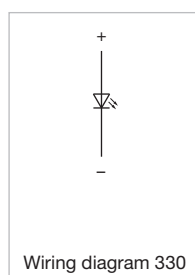

92 Components



Lens plastic

Lens material	Lens colour	Lens optics	Lens shape	Lens illumination	Dimensions	Part No.
Plastic	Black	opaque	flush	non illuminative	13,2 mm x 13,2 mm	92-956.000
	Grey	opaque	flush	non illuminative	13,2 mm x 13,2 mm	92-956.800
	White	opaque	flush	non illuminative	13,2 mm x 13,2 mm	92-956.900
	Yellow	translucent	flush	illuminative	13,2 mm x 13,2 mm	92-956.400
	Green	translucent	flush	illuminative	13,2 mm x 13,2 mm	92-956.500
	Smokey black	transparent	flush	illuminative	13,2 mm x 13,2 mm	92-958.100
	Red	transparent	flush	illuminative	13,2 mm x 13,2 mm	92-958.200
	Yellow	transparent	flush	illuminative	13,2 mm x 13,2 mm	92-958.400
	Green	transparent	flush	illuminative	13,2 mm x 13,2 mm	92-958.500
	Blue	transparent	flush	illuminative	13,2 mm x 13,2 mm	92-958.600
	Colourless	transparent	flush	illuminative	13,2 mm x 13,2 mm	92-958.700

Additional information

- With white marking plate



Lens plate

Dimensions	Lens plate material	Lens plate colour	Lens plate optical effect	Lens plate shape	Lens plate illumination	Part No.
12 mm x 12 mm	Plastic	Black	opaque	flush	non illuminative	92-941.000
	Plastic	Red	transparent	flush	illuminative	92-941.200
	Plastic	Orange	transparent	flush	illuminative	92-941.300
	Plastic	Yellow	transparent	flush	illuminative	92-941.400
	Plastic	Green	transparent	flush	illuminative	92-941.500
	Plastic	Blue	transparent	flush	illuminative	92-941.600
	Plastic	Colourless	transparent	flush	illuminative	92-941.700



Front bezel round, raised design

Front bezel material	Front bezel colour	Material	Colour	Part No.
Plastic	Black	plastic	Black	92-912.0



Single-LED, T1 3/4 MG

Illumination colour	Lumi. Intensity	Dom. Wavelength	Forward voltage	Part No.	Wiring diagram
Red	160 mcd	625 nm	2.0 VDC @ 20 mA	10-2601.3172S	4
Amber	165 mcd	605 nm	2.0 VDC @ 20 mA	10-2601.3173S	4
Yellow	600 mcd	580 nm	2.9 VDC @ 20 mA	10-2603.3174S	4
Green	650 mcd	525 nm	3.2 VDC @ 20 mA	10-2603.3175S	4
Blue	250 mcd	467 nm	3.0 VDC @ 20 mA	10-2603.3176S	4
White	500 mcd	x: 0.31 / y: 0.32 nm	3.2 VDC @ 20 mA	10-2603.3178S	4

Additional information

- The customer has to decide what series resistor shall be used to the LED
- Luminosity and wave length variations caused by LED manufacturing processes may cause slight differences regarding the illumination. The customer has to decide what resistor shall be used to the LED

Wiring diagrams

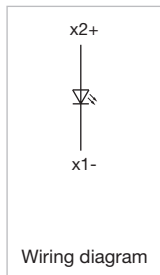

Switching element PCB illuminative

Switching system	Contacts	Contact material	Terminal	Part No.	Wiring diagram	Component Layout
Short-travel element	1 NO	Gold-plated silver	PCB terminal	92-851.342	332	82

Contacts: NO = Normally open

Additional information

- The customer has to decide what series resistor shall be used to the LED
- LED and mounting flange to be ordered separately

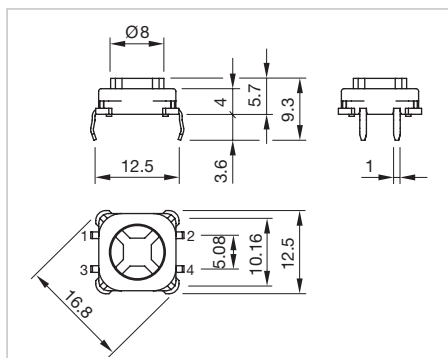

Dimensions [mm]

01
02
03
04
09
14
17
18
19
22
31
41
45
51
56
57
61
70
71
82
84
92
96

92 Components

Wiring diagrams

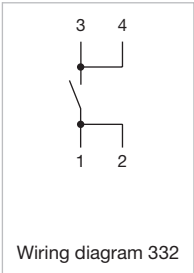

Component layouts

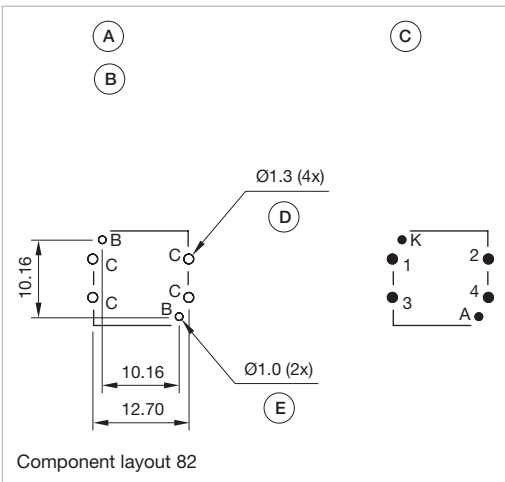

Dimensions [mm]
 A = Switching element with illumination
 B = Single LED
 C = Drilling plan (component side)
 D = Hole for switching element, pad max. \varnothing 2.5 mm
 E = Hole for LED



Indicator element

Terminal	Part No.	Wiring diagram	Component Layout
PCB terminal	92-800.042	330	79

Additional information

- The customer has to decide what series resistor shall be used to the LED
- LED and mounting flange to be ordered separately

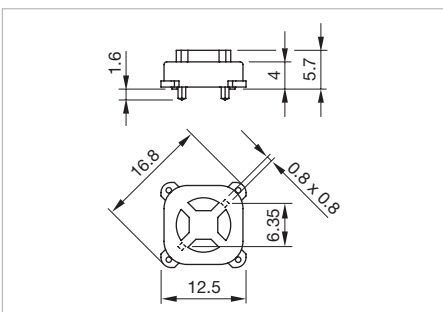

Dimensions [mm]

Wiring diagrams

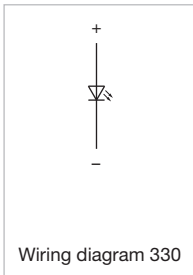

Component layouts

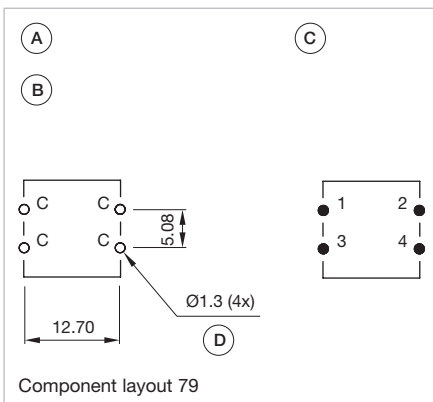

Dimensions [mm]

A = Switching element without illumination

B = Drilling plan (component side)

C = Occupancy plan (component side)

D = Hole for switching element

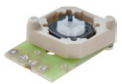

PCB assembled

Material	Part No.	Wiring diagram	Component Layout
metal / plastic	92-981.0	358	92

Wiring diagrams

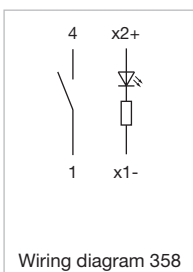

92 Components

Component layouts

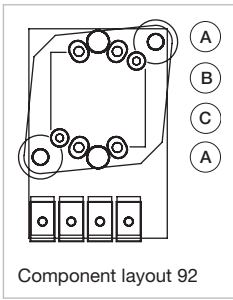

Dimensions [mm]
 A = 4 = Switch
 B = x+ = LED Anode (+)
 C = 1x- = LED Cathode (-)



Mounting flange

Material	Fastening	Part No.
plastic	With screws	92-960.0

Additional information

- For discrete switching applications including switching element and mounting flange, soldering terminal (assembled PCB incl. series resistor and LED on request)

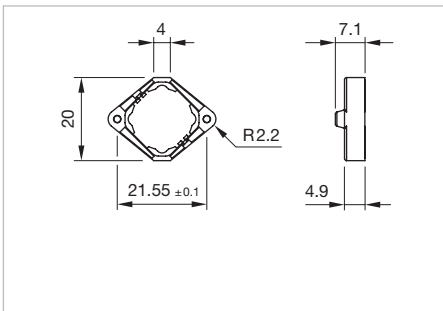

Dimensions [mm]



Anti-twist ring

Material	Mounting cut-out	Part No.
metal	Ø 16.2 mm	51-910

Front side



Blind plug

Dimensions	Material	Colour	Mounting cut-out	Part No.
18 mm x 18 mm	plastic	Black	Ø 16.2 mm	51-948.0

Additional information

- Blind plugs fit also in mounting cut-outs with anti-twist device

01
02
03
04
09
14
17
18
19
22
31
41
45
51
56
57
61
70
71
82
84
92
96



EAO Downloads.
www.eao.com/downloads
EAO creates possibilities. Since 1947.



[On our website you can download technical data, assembly instructions, catalogs, brochures and much more.](http://www.eao.com/downloads)

92 Accessories

Mounting



Dismantling tool

Material	Part No.
metal	92-971.0

Additional information

- For actuator dismantling of switching element, illumination element and mounting flange



Lens remover

Material	Part No.
metal / plastic	18-910



Mounting tool

Product attributes	Dimensions	Material	Part No.
For tightening or loosening of the fixing nut Ø 16 mm	Ø 16 mm	metal	01-907

Pushbutton and Illuminated pushbutton

Switching system

Short-travel switching system with 2 independent contact points and tactile operation.

Guarantees reliable switching even of very light loads.
Fitted with 1 normally open contact.

Material

Lens
Plastic

Front bezel
Plastic

Frame
Plastic

Material of contact
Gold (Au)

Switching element
Plastic

Housing
Plastic

Mechanical characteristics

Tightening torque
Fixing screw mounting flange 0.4 Nm
Fixing nut max. 0.5 Nm

Actuating force
2.7 N ± 1 N measured at the switching element
5 N measured at the lens

Actuating travel
Switching element approx. 0.4 mm

Resistance to heat of soldering
Please see application guidelines

Mechanical lifetime
≥ 1 Million cycles of operation as per IEC 60512-5-9a

Electrical characteristics

Electrical life
500 000 cycles of operation at 42 VDC, 50 mA as per IEC 60512-5-9c.

Electrostatic discharge (ESD)
15 kV

Switching voltage and switching current
Switching voltage min. 50 mV AC/DC
max. 42 V AC/DC
Switching current min. 10 µA AC/DC
max. 100 mA AC/DC
Power rating max. 2 W

Electric strength
500 VAC, 50 Hz, 1 minute, as per IEC 60512-2-4a

Ambient conditions

Storage temperature
−40 °C ... +80 °C

Operating temperature
−25 °C ... +70 °C

Protection
IP40 switching element (fluxproof to DIN 41640 Part 84)
IP67 or IP40 frontside

Shock resistance
(semi-sinusoidal)
Max. 500 m/s², pulse width 11 ms, 3-axis,
as per EN IEC 60068-2-27

Vibration resistance
(sinusoidal)
Max. 100 m/s² at 10 Hz ... 500 Hz, 10 cycles, 3-axis,
as per EN IEC 60068-2-6

Approvals

Approbations
CQC

Conformities
CE
UKCA
2014/35/EU (LVD)
2011/65/EG (RoHS)

92 Marking

General notes

If desired, the actuators of the series 92 can be supplied ready marked. With your order please enclose a list of the desired markings or a drawing, showing the type or size of script or the symbols desired.

1. Engraving (Fig. 1)

With laser marking, the font or symbol is applied directly to the lens applied.

2. Hot stamping (Fig. 1)

For larger series it is worth considering markings by means of hot stamping. We will be pleased to advise you.

3. Film inserts (Fig. 2)

Instead of using engraving, the actuator can be fitted with transparent film inserts. However, for this purpose the use of transparent lens caps is recommended. If smoked lens caps are used the lettering does not become visible until the LED is alight. Max. size of film insert 11.4 x 11.4 mm for IP 40 10.4 x 10.4 mm for IP 67 Film thickness 0.2 mm.

All dimensions in mm

Lens size	Height of letters h	Number of lines	Number of capital letters per line (target value)	Number of small letters per line (target value)
13.2 x 13.2	2.5	3	6	7
	3	3	5	6
	4	2	4	4
	5	2	3	3
	6	1	3	3
	8	1	2	2
12 x 12	2.5	3	6	6
	3	3	5	5
	4	2	4	4
	5	2	3	3
	6	1	2	2
	8	1	2	2

Film insert max. size	Height of letters h	Number of lines	Number of capital letters per line (target value)	Number of small letters per line (target value)
11.4 x 11.4	2.5	3	5	6
	3	2	4	5
	4	2	3	4
	5	1	3	3
	6	1	2	2
	8	1	2	2
10.4 x 10.4	2.5	3	5	5
	3	2	4	4
	4	2	3	3
	5	1	2	3
	6	1	2	2
	8	1	1	1

Fig. 1

Fig. 2

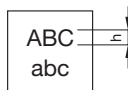
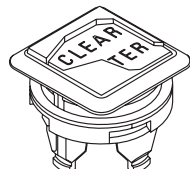

Suppressor circuits

When switching inductive loads such as relays, DC motors, and DC solenoids, it is always important to absorb surges (e.g. with a diode) to protect the contacts. When these inductive loads are switched off, a counter emf can severely damage switch contacts and greatly shorten lifetime.

Fig. 1 shows an inductive load with a free-wheeling diode connected in parallel. This free-wheeling diode provides a path for the inductor current to flow when the current is interrupted by the switch. Without this free-wheeling diode, the voltage across the coil will be limited only by dielectric breakdown voltages of the circuit or parasitic elements of the coil. This voltage can be kilo-

volts in amplitude even when nominal circuit voltages are low (e.g. 12 VDC) see Fig. 2.

The free-wheeling diode should be chosen so that the reverse breakdown voltage is greater than the voltage driving the inductive load. The DC blocking voltage (V_R) of the free-wheeling diode can be found in the datasheet of a diode. The forward current should be equal or greater than the maximum current flowing through the load.

To get an efficient protection, the free-wheeling diode must be connected as close as possible to the inductive load!

Switching with inductive load
Fig. 1

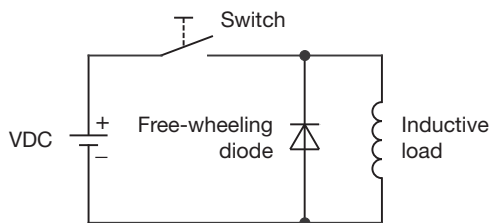

Counter EMF
over load without free-wheeling diode
Fig. 2

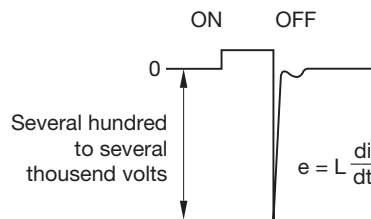

Note for soldering

Process parameter for wave soldering

Basic specification for wave soldering J-STD 75 W4C.

Maximum temperature on the component side (Temp 2):
(Temperature must not exceed during the entire processing)

120 °C

Preheating phase (t1 ... t2):

70 ... 120 sec

Ramp up:

typ. +1 °C/sec

Ramp up to maximum temperature (t2 ... t3):

not defined

Maximum temperature on the soldering side (Temp 3):

250 °C

Maximum time of soldering process (t3 ... t4):

3 sec

Ramp down at 170 °C:

typ. -2 °C/sec

92 Application guidelines

Temperature curve wave soldering

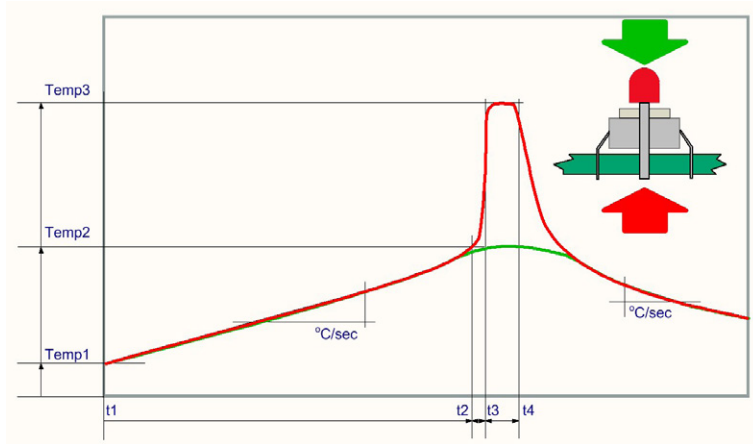

Green curve: Temperature on the component side of the pcb
 Red curve: Temperature on the soldering side of the pcb

Room temperature: Temp 1

Preheating: Temperature process = Temp 1 ... Temp 2
 Process time = t1 ... t2

Ramp up to soldering temperature: Process time = t2 ... t3

Soldering phase: Temperature process = Temp 3
 Process time = t3 ... t4

Iron soldering

Basic specification for iron soldering IEC 60068-2-20

Maximum temperature at tip of iron: 320 °C
 Maximum soldering time: 3 sec

Cleaning/Lacquering

The switching elements are not sealed. Cleaning up the PCB may damage the contacts in the switching elements. For this reason, the following points should be noted:

- When soldering make sure that the flux does not pass on the upper side of the PCB.
- When cleaning the PCB with detergents ensure that no dust or other debris may get inside of the switching elements.
- Ensure that no lacquer penetrates into the interior of the switching element when lacquering the PCB.

Storage of components

To obtain the optimum solderability of the components, the following points should be noted during storage:

- Do not store components in locations with high temperature or humidity.
- Do not expose components to corrosive gases.
- Avoid direct sunlight for a long period.

Arrangement mounting flange for switching- and illumination element, PCB mounting

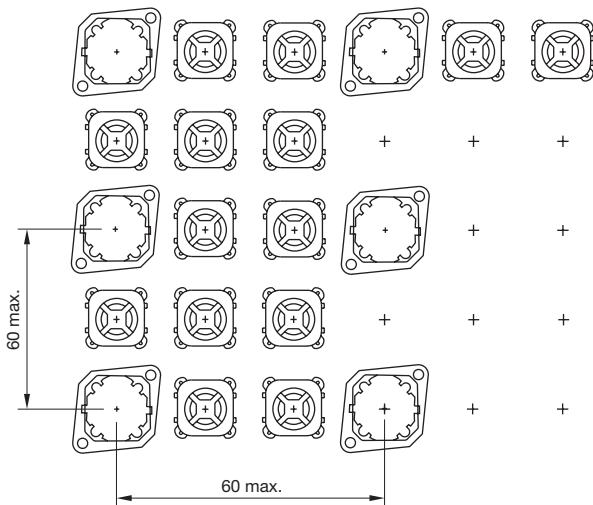

The arrangement of the mounting flanges and their number is determined by the size of the front panel or PCB. To ensure uniform, tactile switching, we recommend a layout of the flanges as per adjacent sketch.

For large PCBs with several switching elements we recommend the following procedure:

1. Fit the actuator to the front panel.
2. Clip the mounting flange to the rear of the intended actuator.
3. Screw the PCB with the components soldered to it to the assembled mounting flange.

This arrangement applies to PCBs 1.6 mm thick.

Dismantling mounting flange

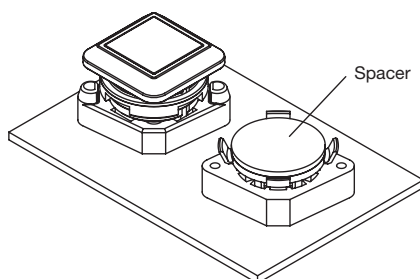
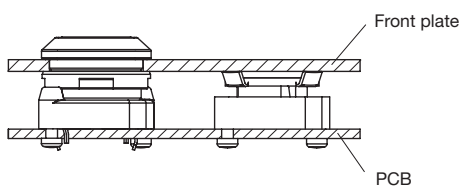

The tool Part No. 92-971.0 must be used for removing the mounting flange from the actuator. Before removing the flange, the PCB fixing screws must be loosened.

If the number of actuators is insufficient, use the spacer Part. No. 92-965.0 which can be attached to the front panel.

The spacer can be adjusted to the following front panel thicknesses: 1.5/2/2.2/3/3.5/4 mm and can be stuck to the back of the panel free of dirt and grease.

