

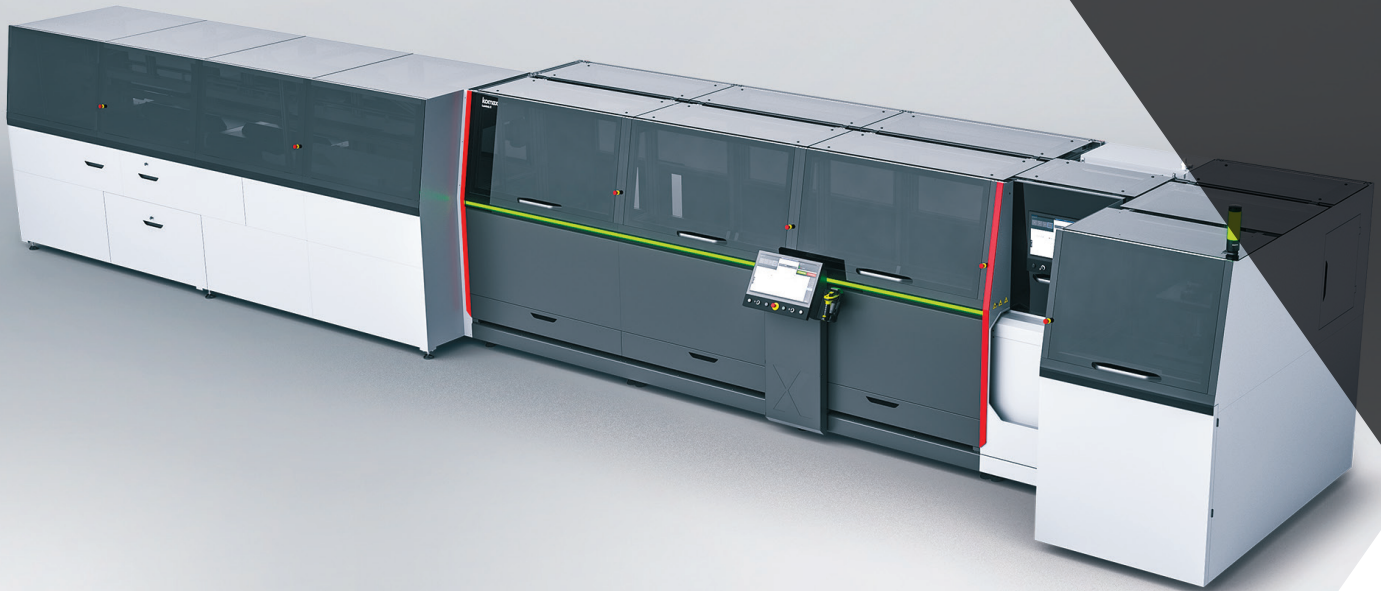

LAMBDA X

automated platform data wire





The LambdaX is a modular machine base for semi- and fully automatic assembly of multistage contact systems. The modular structure of the machine in terms of hardware, machine control and visualization enables an efficient and intuitive operation. The process modules are freely configurable and can be lined up regarding the assembly requirements of different connector systems and wire types. Due to the modularity of the platform the degree of automation can be increased on site in case of higher production volumes (e.g., upgrade of manual insertion to fully automatic wirefeed).

Basic modules

- Supply cell
- Process cell 1.5 m
- Process cell 3.0 m
- Deposition



- Your benefits**
- Minimal space requirement thanks to innovative transfer system
 - Possibility to increase the automation level during ramp-up
 - Freely scalable process level due to modular structure
 - Increase of production volume
 - Processing of extremely short wire lengths up to 90 mm
 - Minimal cycle times up to 4.5 s
 - Low productions costs thanks to innovative transfer system
 - Easy functional extension
 - Outstanding and process stable processing thanks to welded frame
 - Fast change of production due to simple and configurable jobs
 - Less training efforts thanks to modularity
 - Integrated job management with included statistics and capability analysis
 - User management for managing user rights
 - Less warehouse costs because of standardized structure

Digital Services

- WIRE Insights**
- Real-time processing of production data
 - Visualization in clear graphics
 - Report generation with relevant statistics
- MES Lambda Interface Plugin**
- Connection to internal production management systems
 - Improving traceability
 - Increase quality through continuous process improvement
- Optional traceability plugin**
- Saving of all quality measurement data according to produced cable
 - Export of all result data as .csv-file

Applications

- Automotive Ethernet
- Coaxial connector systems
- High speed data
- High voltage up to 6 mm²

Exemplary machine LambdaX (without modules):
Supply cell, 1,5 m process cell, 3,0 m process cell,
batch deposit with manual removal

- 01 Transfer system
- 02 Workpiece carrier
- 03 Quality overview
- 04 Movable control unit



01

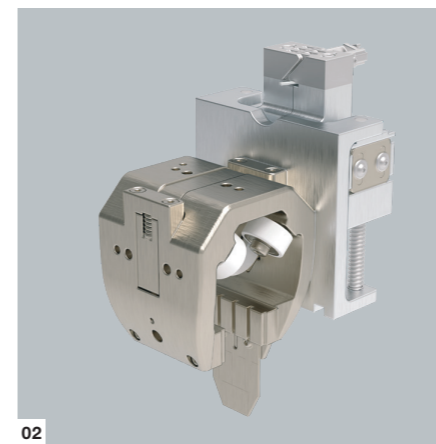

02

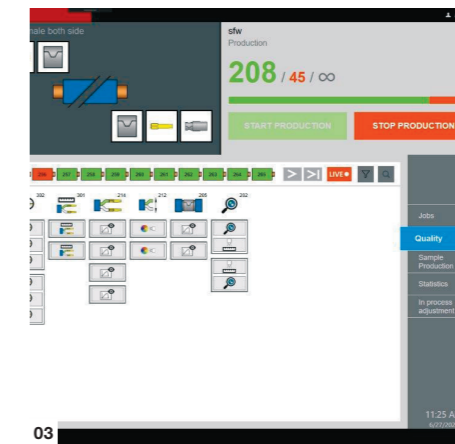

03



04



01
02



- 01** Optionally a movable and tiltable control unit can be installed in front of the machine which can be moved manually over the entire process level.
- 02** To read in batches and consumables the option for a barcode scanner is available.
- 03** With the small deposit, bad parts can be separated from good parts and stored in batches. The parts are removed manually via a pull-out container.
- 04** For maximum autonomy a fully automatic deposit system with conveyor belt can be integrated. The side of extraction of good parts can be selected in front or rear.

03
04





01
02

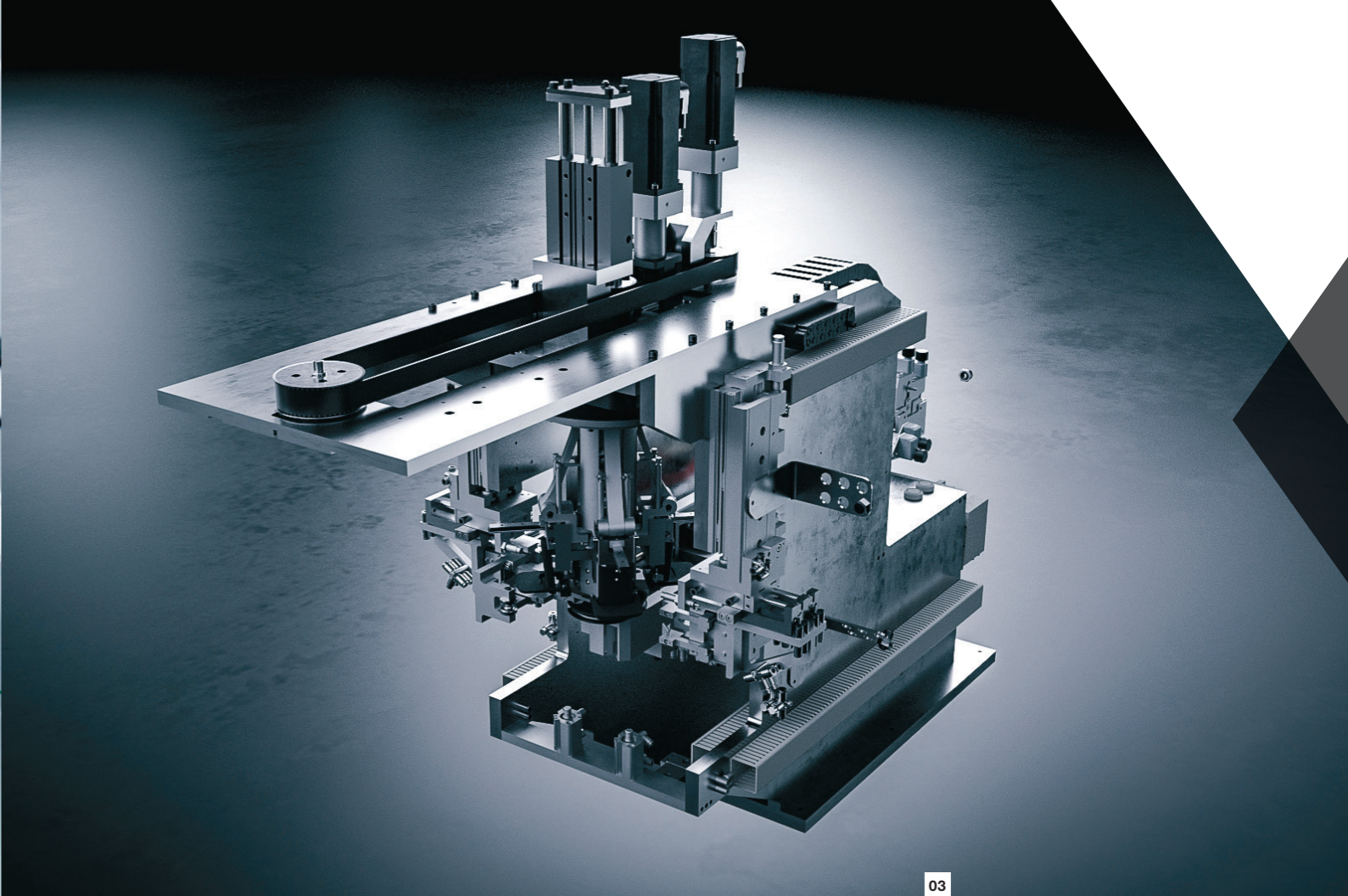

03



01
With the function manual wire insertion, it is possible to insert the cables one sided or both sided. Additionally, wires can be inserted already pre-assembled on one side.

02
To increase the autonomy of the machine a fully automatic wire feed system can be integrated to reach maximum productivity.

03
The innovative coiling system enables a fully automatic and precise winding and fixing of long cables (<15 m) into coils. In combination with the automatic wirefeed, the entire process can be covered fully automated within the Lambda X.

Komax – leading the field now and in the future

As a pioneer and market leader in automated wire processing, Komax provides its customers with innovative solutions. Komax manufactures series and customer-specific machinery, catering to every degree of automation and customization. Its range of quality tools, test systems, and intelligent software and networking solutions complete the portfolio, and ensure safe, flexible, and efficient production.

Komax is a globally active Swiss company with highly qualified employees and development and production facilities on several continents. It provides local support to customers worldwide through its unique sales and service network and offers services that help them get the most out of their investments.

Komax AG
Industriestrasse 6
6036 Dierikon, Switzerland
Phone +41 41 455 04 55
sales.din@komaxgroup.com

komax
komaxgroup.com