

**KITE GOOD COMPANY**

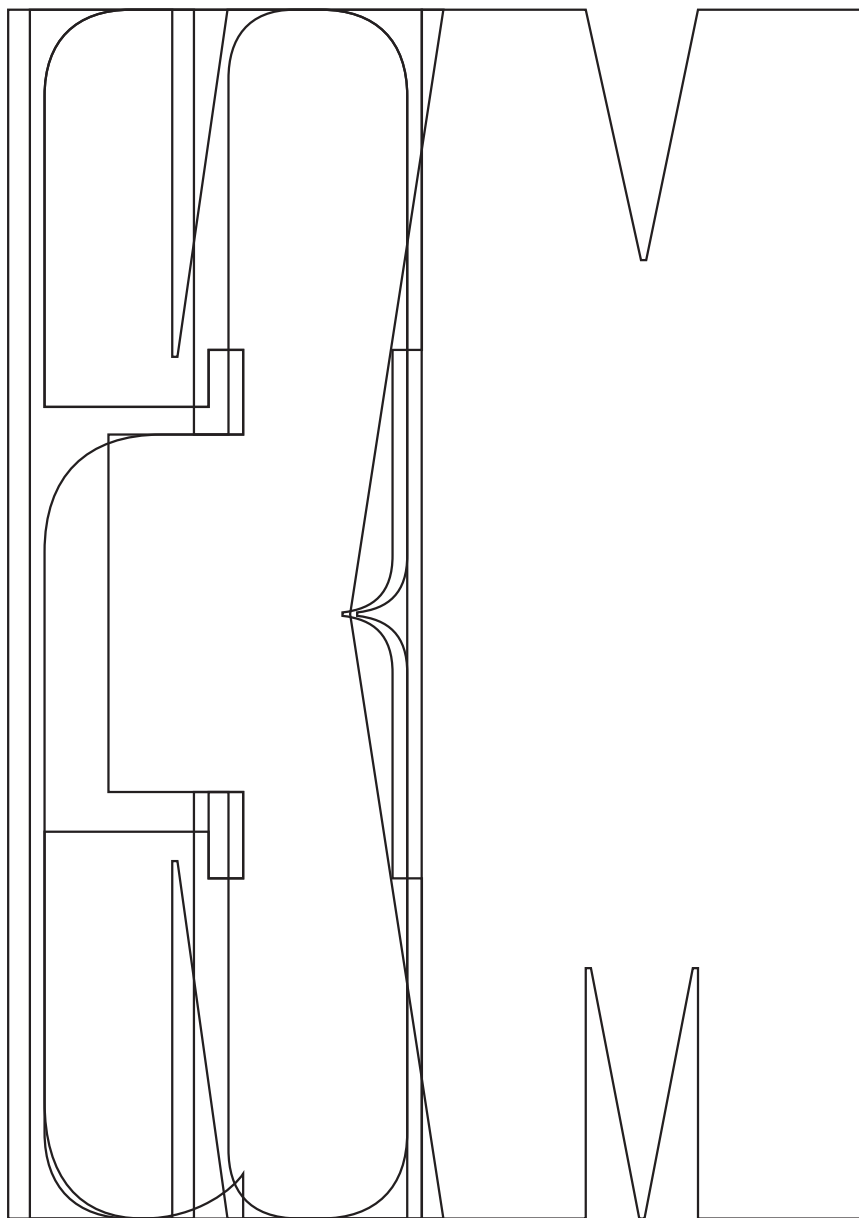

KTF Compact have been drawn based on a movie poster “Влюблен по Собственному Желанию”, found by Kirill Gluschenko, issued by Reklamizdat in 1982. It is a display typeface of ultimate heaviness, that exists on the edge of readability. Its shapes are mostly made of a vertical rectangle of the same width, slightly rounded, and spaced in the tightest manner of 5 Points. When typeset, Compact reminds on wooden blocks toy set from the childhood, yet strictly vertically arranged in lines. However, Compact is an invitation to play. We may say, KTF Compact is the typographic Roland 909\*: simple and effective in creating sequences. It is anything but mechanical, being one of a kind that takes the space and inverts it. Compact becomes a surface. All the life and surprises start to happen not in black on white, but vice versa: “within” blocks and in hairline-alike spaces between them. And don’t forget, it does its job perfectly only when being big, just like BelAZ in the mine.\*\*

An Israeli-born designer Matan Iontef accomplished the Hebrew part of KTF Compact in 2023. He took inspiration from his research in woodtype culture across Israel, adapting and remixing the found forms within the given system. Working with the script almost contradicting the nature of Compact, and accepting the challenge to maintain a similar typesetting texture as in Cyrillic and Latin, he did a few grid alterations, so the result became legible and cohesive within a multiscriptual typesetting context. Compact Hebrew contains a specially coded set of diacritic marks (niqqud, Hebrew vowels system) to supplement the spirit and style of the font. Matan’s favorite metaphor for the spirit of the font comes from football: “Unlike Yoram Arbel’s famous expression, Compact is a perfect example of how a wall should be built!\*\*\*”

\*The Roland TR-909 Rhythm Composer is a drum machine from 1983 that became influential in the development of electronic dance music genres such as techno, house, and acid.

\*\*BelAZ is one of the largest dump trucks in the world, produced in Belarus.

\*\*\*“This is not how you build a wall” is a famous Hebrew phrase coined during a 1989 soccer match between Australia and Israel by Yoram Arbel, referring to a wrong and negligent way of doing things.

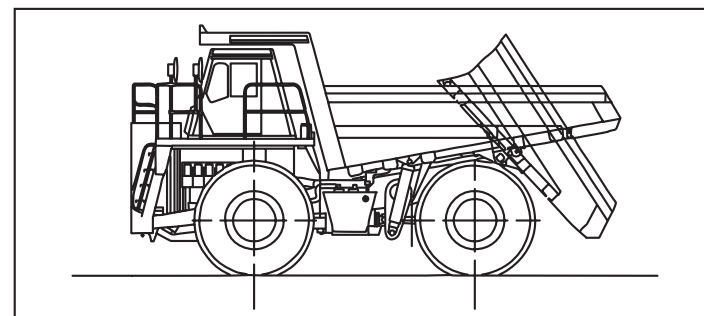
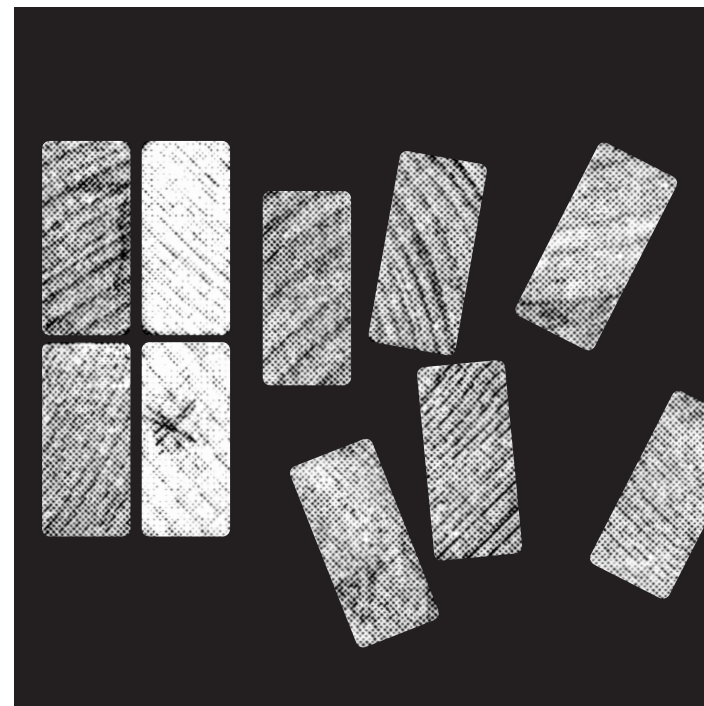

ss01: Alternative numbers



ss02: Alternative arrows

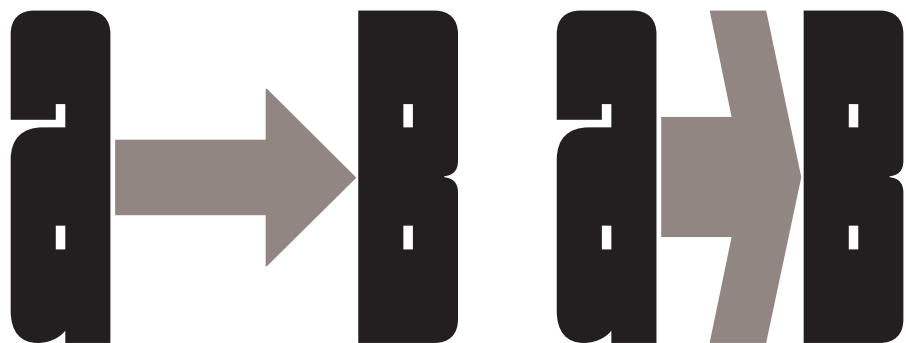

Kazakh, Tatar, Turkish, Azeri



German



ss03: Alternative ampersand

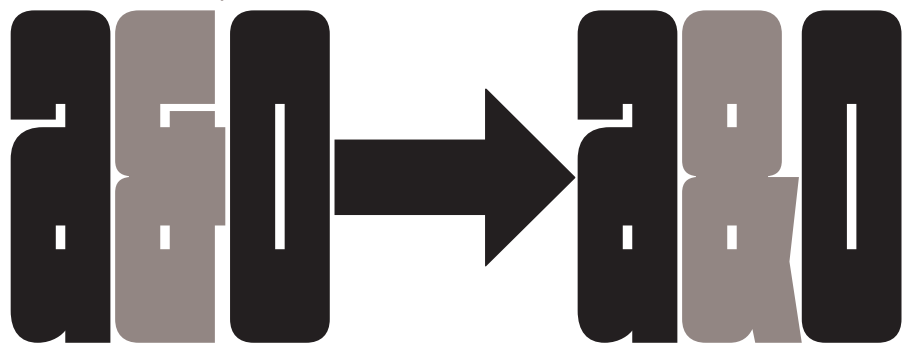

Romanian, Moldavian

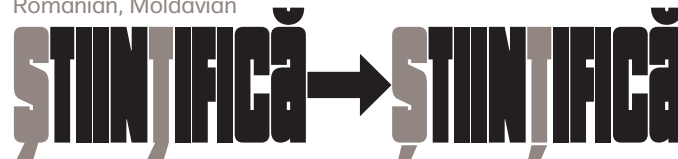

Ukrainian

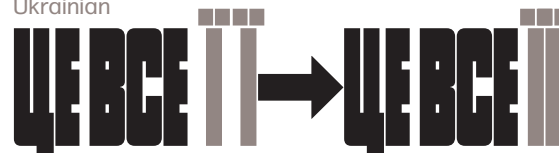

Ligatures



W31S XWHEELER

CELÄNDEWAGEN

**SMPLER**

**LOST EMMALS**

ПОЗІВІЯ ЗРІЛЛИХ ШУКАВЬ»

НОЗІ ЗАЧАРОВАНА ДІВКА

↑ HOT ZONE! \* THE BIG SLEEP

DURCH DIE NACHT INFOAKTE



**A B C D E F G H I J K L M N O P Q R S T U V W X Y Z**

**0 1 2 3 4 5 6 7 8 9**

CAFÉ BRÁO ÉTÉ SPRÁK

HA ZOE SCHLIERUNG!

PIĚC AOÛT ATŠKIRIGS

**DANGER**

ХАРНВУ ХРНВУ

ОДЕСА ↓ ЛЬВІВ

ss02

**MAD-7022**  
**HPAD-255**

**ss01**

OPPAHNEHUTPAGECE

ORANIENSTRASSE 15

SS01

НЕМНОГО  
НЕМНОГО

НВР-СВНТОН

**WORLD**



АКАДЕММІСТЕЧКО

ЖИТОМИРСЬКА

СВЯТОШИН

НИВКИ

БЕРЕСТЕЙСЬКА

ШУЛЯВСЬКА

ПОЛІТЕХНІЧНИЙ ІНСТ.

ВОКЗАЛЬНА

УНІВЕРСИТЕТ

ГЕРОІВ ДНІПРА

МІНСЬКА

ОБОЛОНЬ

ПОЧАЙНА

ТАРАСА ШЕВЧЕНКА

КОНТРАКТОВА ПЛОЩА

ПОШТОВА ПЛОЩА

МАЙДАН НЕЗАЛЕЖНОСТІ

ПЛОЩА ~~ТАРАСА~~

ДОРОГОЖИЧІ

ЛУК'ЯНІВСЬКА

ЗОЛОТІ ВОРОТА

ПАЛАЦ СПОРТУ

КЛОВСЬКА

ПЕЧЕРСЬКА

~~ДРУЖБА НАРСІВ~~

ВИДУБИЧІ

СЛАВУТИЧ

**TWNEODWNTH**



BRAND

ss04: Alternative Tsadi

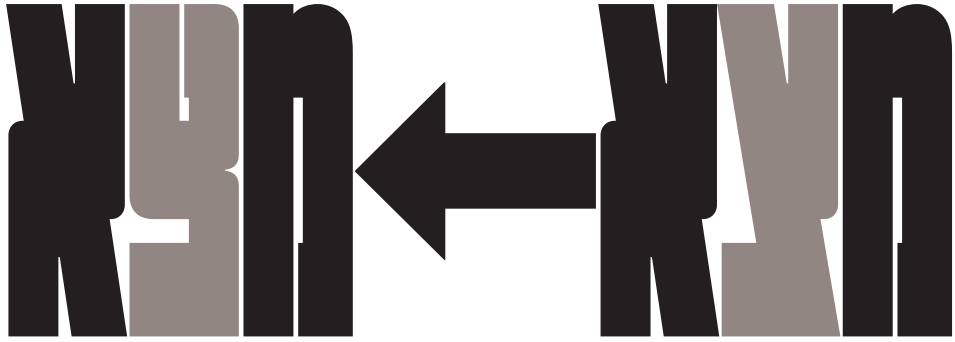

ss05: Alternative Tet

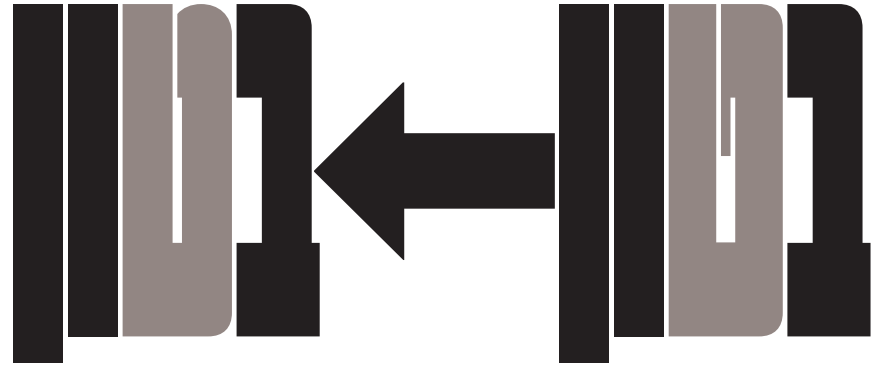

ss05: Alternative Mem

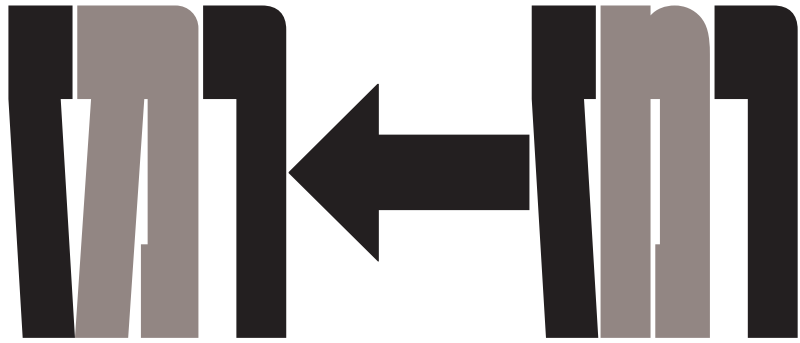

ss06: Alternative Yod, Vav, Final Nun

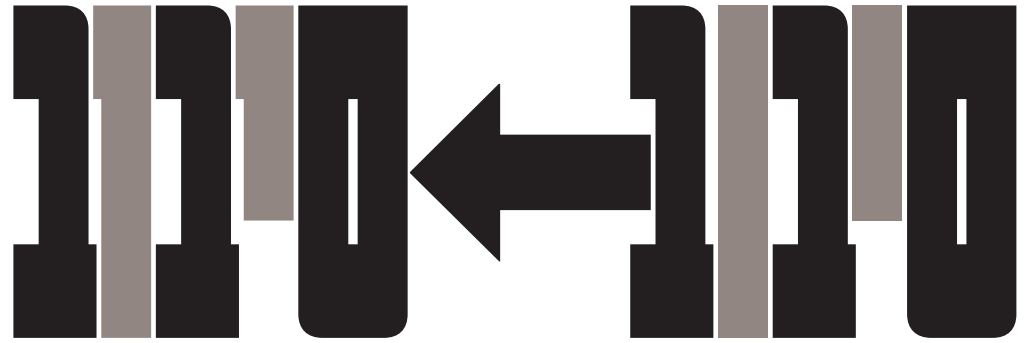

ss07: Alternative Shin

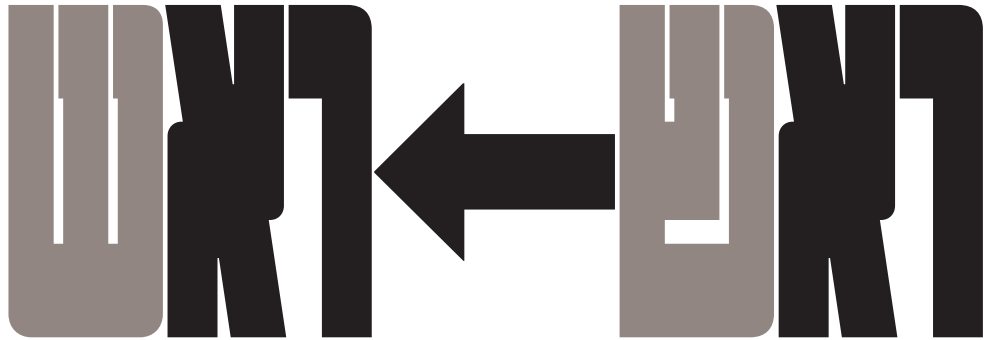

Niqqud:



WINDTALK

חסיבת השנה  
 חול טובטוי  
 צפוף באון  
 חטדון דיקודים  
 טראפיה פהופ  
 חזיקה אנקטרונית  
 חלום בנהות  
 פלסטיק סאם

ירוק העונה  
 אחצטי אומותי  
 יפו תל אביב  
 שיפוציג  
 שנות שפירא  
 עפיפון בלי חוט  
 אוקסימורן  
 ארוחת חלבים

אינציקלופדיה  
 חסוכי!  
 חולטידיסיפלנות  
 אימפרטיביסטים  
 שושנת הרוחות  
 קוצרט  
 תקשורת חזתית  
 עונת השנה

**WAG**

ДИНОЗАВР

דִּינוֹזָאָוּר

DINOSAUR

МАКАРОНИ

מַכָּאָרוֹנִי

MACARONI

ОКУЛЯРИ

אֲנִימָטִיקָה

GLASSES

СИМФОНИЯ

סימפוניה

SYMPHONY





STW STW STW STW  
STW STW STW STW  
STW STW STW STW  
STW STW STW STW

ss07

ss07

ss04





וְהָאֵלֹהִים בְּרַקְעַנְשָׁמַיִם.

לְהַבְדִּילֵנוּ בְּיַמֵּי הַיּוֹם וּבְיַמֵּי הַלַּיְלָה.



דג סקרן שטע ביים אן ולפתע מצא חבד הזה  
וען יצחק הטעיים, מתשופק נושר גדול  
בין שתיים ארץ נר התרסק ופיץ  
שעל גזעל קטן שדחק את צבי למים.

Punctuation	—	-	—	—	•	•	*	•	☰	•	•	•	•	•	•	•	•	•	•
<	>	«	»	/		\	[	]	{	}	#	!	!	?	?	!	!	!	!
C	D	E	F	G	H	I	J	K	L	M	N	O	P	Q	R	S	T	U	V
W	X	Y	Z	á	â	ã	ä	å	æ	ç	ø	è	é	ê	ë	ì	í	î	ï
ĭ	ñ	ò	ó	ô	ö	õ	ø	ù	ú	û	ü	ý	ÿ	þ	ß	à	á	â	ã
č	ć	ĉ	ċ	ď	đ	ē	ĕ	è	é	ê	ë	ĝ	ġ	ĥ	ĥ	ĥ	ĥ	ĥ	ĥ
ı	ï	ı	ı	ı	ı	ı	ı	ı	ı	ı	ı	ı	ı	ı	ı	ı	ı	ı	ı
á	ö	ö	œ	á	ř	ř	š	š	š	š	š	š	š	š	š	š	š	š	š
ç	ô	ü	ŵ	ŵ	ŵ	ŵ	ŷ	ŷ	ŷ	ž	ž	ž	ž	ž	ž	ž	ž	ž	ž
ж	з	н	й	к	л	м	н	о	п	р	с	т	у	ф	х	ц	ч	ш	щ
ь	ы	ь	з	ю	я	г	г	ф	а	è	ж	ı	ı	ı	ı	ı	ı	ı	ı
ь	н	ь	а	в	с	һ	һ	у	у	ү	ф	х	ц	ч	һ	е	е	е	е
2	3	4	5	6	7	8	9	2	3	4	5	6	9	×	÷	÷	÷	÷	÷
¥	π	Δ	ε	Math operators		/	/		◊	+	±	×	-	÷	=	≠	≠	≠	≠

Basic Latin

Latin-1

Extended Latin

Basic Cyrillic

Extended Cyrillic

Numbers

Currency and science



∞	∞	∞	∞	∞	∞	∞	∞	'	"	°	%	‰	Superscript and fractions			1/2	1/4	ONE/HALF	ONE/QUARTER		
THREE/QUARTERS		Arrows		↑	↗	→	↘	↓	↙	←	↖	↔	↕	↑	↗	↘	↓	↙	←	↖	
↔	↕	Misc symbols		U	U	TM	Q	Y	NO	£	&	§	†	‡	e	hebrew		1	2	3	4
1	2	3	4	5	6	7	8	9	0	1	2	3	4	5	6	7	8	9	0	1	2
U	U	hebrew composites		U	U	U	U	U	U	U	U	U	U	U	U	U	U	U	U	U	U
U	U	U	U	U	U	U	U	U	U	U	U	U	U	U	alt composites		U	U	U	U	U
U	U	U	Niqqud														hebrew punctuation				

Encoding  
Latin Extended  
Cyrillic  
Hebrew

Language coverage Hebrew  
Bukharic, Eastern Yiddish, Hebrew, Judeo-Persian, Western Yiddish

File Formats  
otf, ttf, woff

Language coverage Cyrillic  
Adyghe, Avaric, Belarusian, Bulgarian, Chechen, Crimean Tatar, Dargwa, Halh Mongolian, Kabardian, Kazakh, Kirghiz, Kumyk, Lezghian, Macedonian, Montenegrin, Russian, Rusyn, Serbian, Tajik, Tatar, Ukrainian

Version 1.2

Design  
Cyrillic, Latin: Yevgeniy Anfalov, 2020–2023  
Hebrew: Matan Iontef, 2022–23

Language coverage Latin  
Afrikaans, Albanian, Asturian, Asu, Basque, Bemba, Bena, Breton, Catalan, Chiga, Colognian, Cornish, Croatian, Czech, Danish, Dutch, Embu, English Esperanto, Estonian, Faroese, Filipino, Finnish, French, Friulian, Galician, Ganda, German, Gusii, Hawaiian, Hungarian, Icelandic, Igbolnari, Sami, Indonesian, Irish, Italian, Jola-Fonyi, Kabuverdianu, Kalaallisut, Kalenjin, Kamba, Kikuyu, Lakota, Langi, Latvian, Lithuanian, Lower Sorbian, Luo, Luxembourgish, Luyia, Machame, Makuwa-Meetto, Makonde, Malagasy, Maltese, Manx, Meru, Morisyen, North, Ndebele, Northern Sami, Norwegian Bokmål, Norwegian Nynorsk, Nyankole, Oromo, Polish, Portuguese, Prussian, Quechua, Romanian, Romansh, Rombo, Rundi, Rwa, Samburu, Sango, Sangu, Scottish Gaelic, Sena, Serbian, Shambala, Shona, Slovak, Slovenian, Soga, Somali, Spanish, Swahili, Swedish, Swiss German, Taita, Tasawaq, Teso, Tongan, Turkish Upper, Sorbian Uzbek, Volapük, Vunjo, Walser, Welsh, Western, Frisian, Yoruba, Zarma, Zulu

Contact  
info@kyivtypefoundry.com  
Kyiv Type Foundry  
Goldener Winkel 4 30159 Hannover, Germany  
+49 (0)162 795 98 69  
www.kyivtypefoundry.com

No part of this publication may be reproduced, stored in a retrieval system, or transmitted, in any form or by any means, electronic, mechanical, photocopying, recording or otherwise, without the prior written consent of the publisher.