

Demirel Crimp Technik GmbH



we connect the world

Demirel Crimp Technik

- ▶ Private owned company
- ▶ More than 40 years on the market
- ▶ Well-known supplier for most of the wire harness maker in Europe and worldwide
- ▶ OEM supplier for applicators, presses wearing parts and special machines
- ▶ Certified according to DIN EN ISO 9001
- ▶ Production sites in Germany and Slovakia with independent development and sales departments
- ▶ Sales offices in Mexico, Morocco, Romania, Serbia, Turkey, Tunisia and Ukraine

Demirel Crimp Technik

- ▶ More than 260 employees worldwide
- ▶ State-of-the-art 3D-CAD workplaces
- ▶ 8.100 m² (~87,200 sq.ft.) air-conditioned production area
- ▶ Depth of production of about 85 % with up-to-date production technologies
 - ▶ 5-axis HSC milling centers (High Speed Cutting)
 - ▶ High-precision wire eroding machines
 - ▶ CNC grinding machines and CNC turning machines
- ▶ Air-conditioned measuring room with modern optical and tactile measuring systems
- ▶ High speed camera for analyzing crimp processes

Company History - Milestones



Locations



Germany
development, manufacturing, sales



Slovakia
development, manufacturing, sales



Romania
sales and service



Turkey
sales and service



Tunisia
sales and service



Mexico
sales and service



Serbia
sales and service



Morocco
sales and service



Ukraine
sales and service

Locations

Germany

- ▷ 1,100 m² (~11,840 sq.ft.) administration
- ▷ 3,300 m² (~35,520 sq.ft.) production area
- ▷ 94 employees
- ▷ Production (applicators, wearing parts,...)
- ▷ Development and construction (applicators)
- ▷ Order processing
- ▷ After-sales service

Romania

- ▷ 2 employees
- ▷ Distribution Romania
- ▷ After-sales service

Tunisia

- ▷ 1 employee
- ▷ Distribution Tunisia, Egypt
- ▷ After-sales service

Slovakia

- ▷ 1,000 m² (~10,780 sq.ft.) administration
- ▷ 4,800 m² (~ 87,200 sq.ft.) production area
- ▷ 161 employees
- ▷ Production (crimp presses and special machinery)
- ▷ Development and construction (crimp presses and special machinery)
- ▷ After-sales service Eastern Europe

Turkey

- ▷ 2 employees
- ▷ Distribution Turkey and Bulgaria
- ▷ After-sales service

Locations

Serbia

- ▷ 1 employee
- ▷ Distribution Serbia and North Macedonia
- ▷ After-sales service

Mexico

- ▷ Location León
- ▷ 1 employee
- ▷ Distribution Mexico
- ▷ After-sales service

Ukraine

- ▷ 1 employee
- ▷ Distribution Ukraine
- ▷ After-sales service

Morocco

- ▷ Location Tanger
- ▷ 1 employee
- ▷ Distribution Morocco
- ▷ After-sales service

Demirel Crimp Technik, Germany

Company premises in Zittau



Demirel Crimp Technik, Germany



Exhibition room



Applicator mounting places



5-axis machining center with robot



Wire eroding machines

Hanke Crimp-Technik, Slovakia

Location Michalovce - SK



Hanke Crimp-Technik, Slovakia



Work preparation department



Assembling



Stocks



Production

Demirel Crimp Technik

OEM - Original Equipment Manufacturer - Status

- ▶ Demirel Crimp Technik GmbH is the official supplier of crimp applicators with OEM status for the following terminal manufacturers:



KOSTAL



SCHULTE&CO
automotive components



Competence in Connectors

Rosenberger

DELPHI

Klauke[®]
A Textron Company

Product Range

▶ **Applicators**

- ▶ From 0.03 mm² to 100 mm² (300 mm²)
- ▶ For all kinds of terminals (strip form, single terminals, machined terminals)
- ▶ Special applicators (f.e. forged battery terminals)
- ▶ OEM-style applicators and wear parts

▶ **Crimp presses**

- ▶ Up to 300 mm²
- ▶ With stripping units, crimp force monitoring, defective crimp cutting system or seal mounting stations
- ▶ Special machinery (customer-made machines)

Side Feed Applicators

QUICK – CRIMP 947

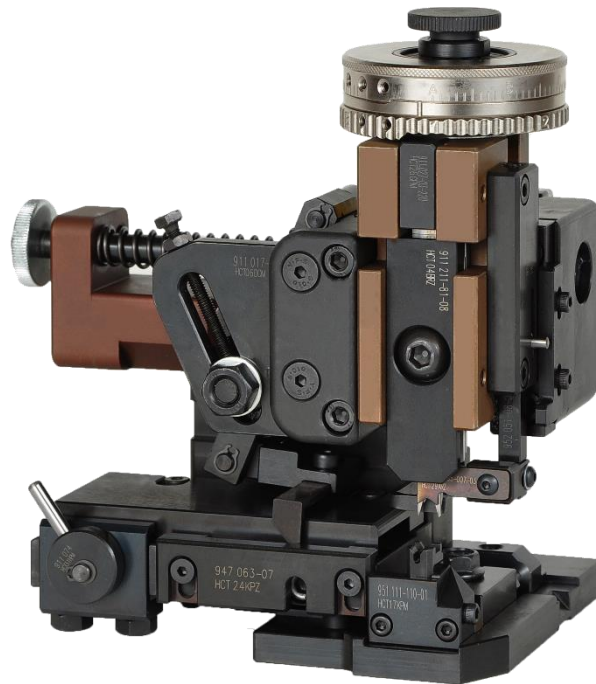

Mechanical feed

GLOBAL – STAR 951



Pneumatic feed

Wire cross-section: 0.08 mm² - 6 mm² / Shut height: 135.78 mm

Rear Feed Applicators

QUICK – CRIMP 948



Mechanical feed

GLOBAL – STAR 952



Pneumatic feed

Wire cross-section: 0.08 mm² - 6 mm² / Shut height: 135.78 mm

Applicators Innovation

651 RED Line

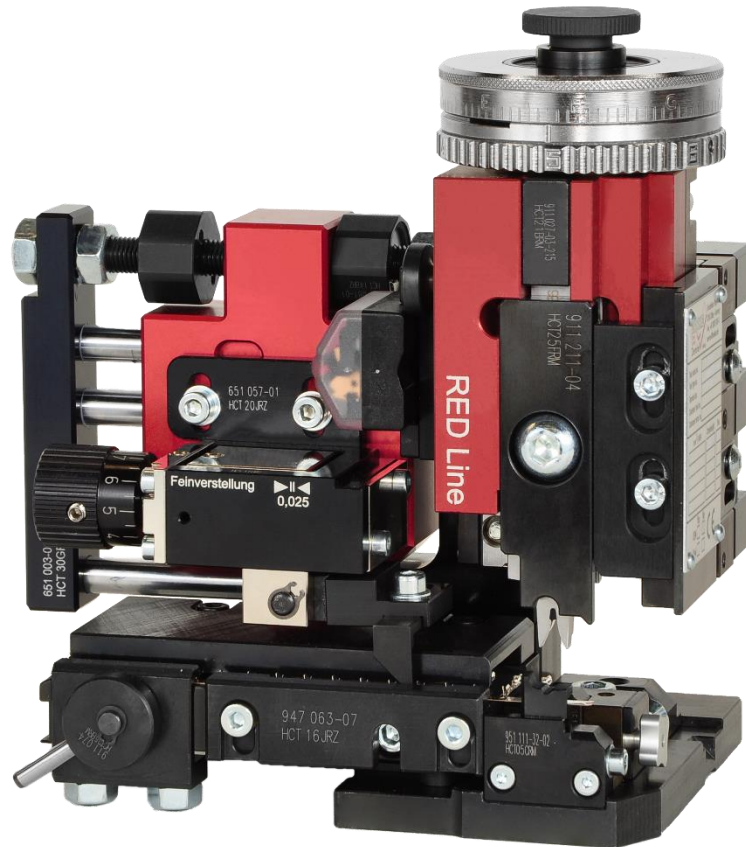

High precision quick change crimp applicator for very small cross sections

Wire cross-section: 0.08 mm² - 2,50 mm² / Shut height: 135.78 mm

Applicators Innovation

651 GOLD Line

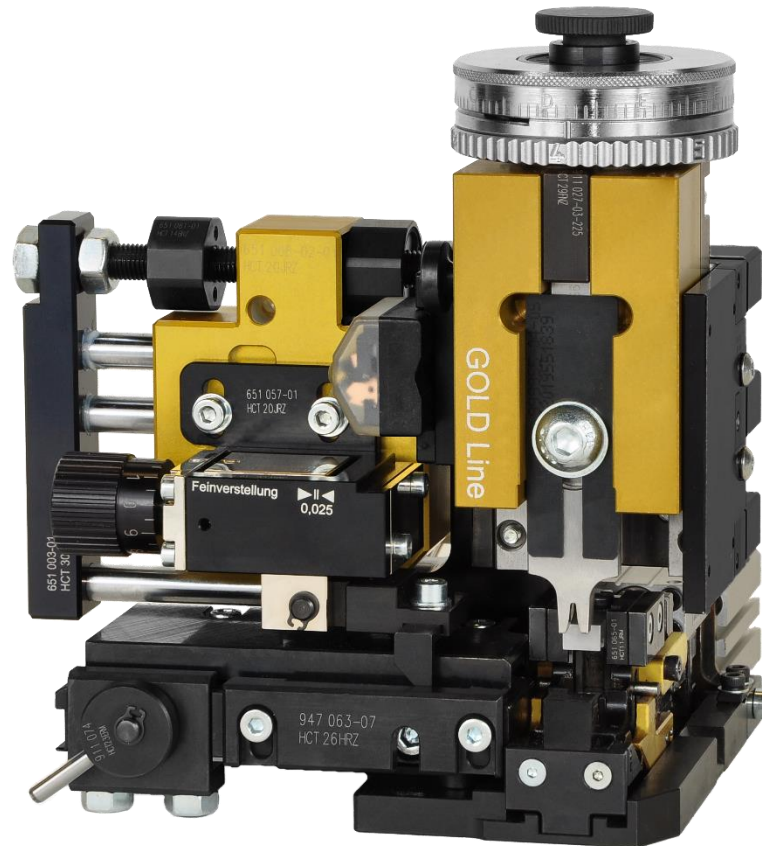

High precision quick change crimp applicator for shortest dismantle lengths

Wire cross-section: 0.08 mm² - 2,50 mm² / Shut height: 135.78 mm

Midrange Side Feed Applicator

POWER – CRIMP 925



Pneumatic Side Feed – shut height 135.78 mm - up to 16 mm²
(depends on material thickness)

Midrange Rear Feed Applicator

POWER – CRIMP 926

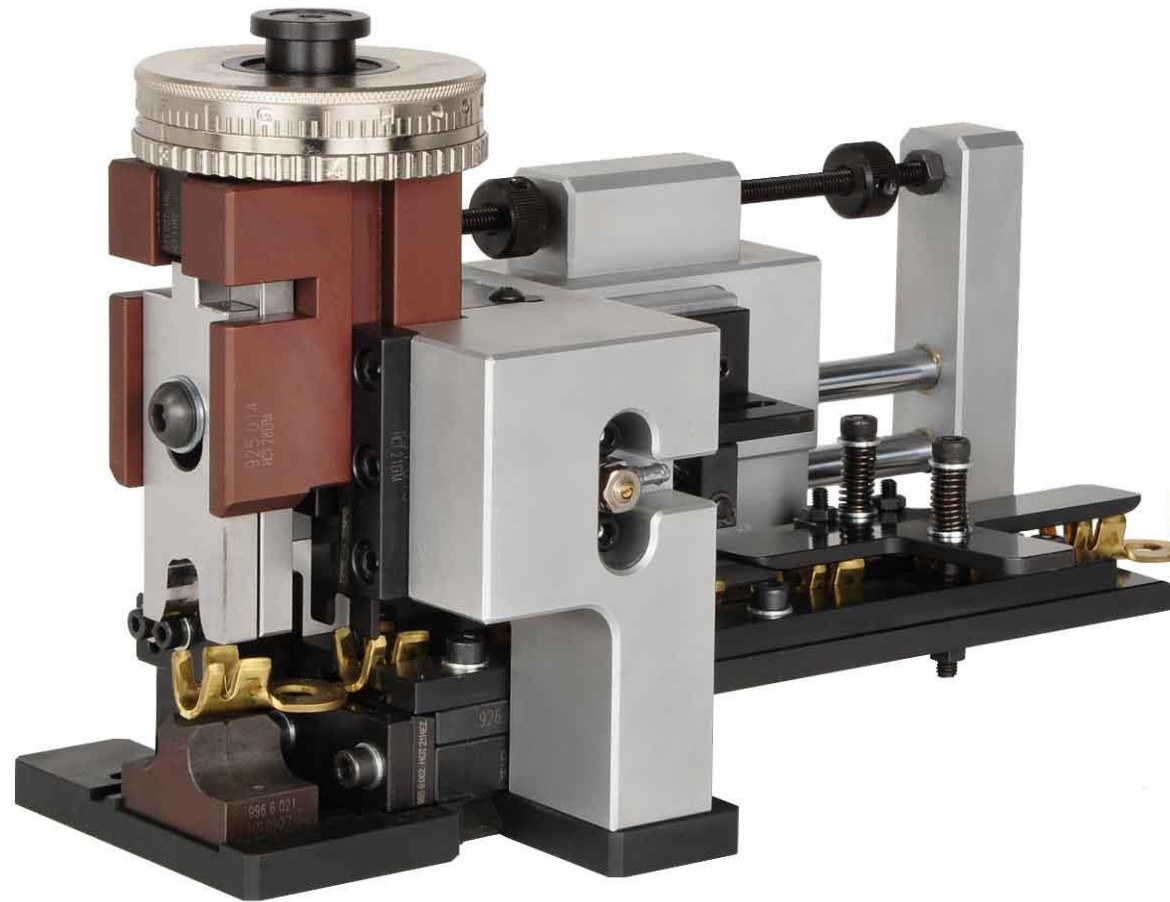

Pneumatic end feed – shut height 135.78 mm – up to 16 mm²
(depends on material thickness)

Midrange Side Feed Applicator

POWER – CRIMP 936

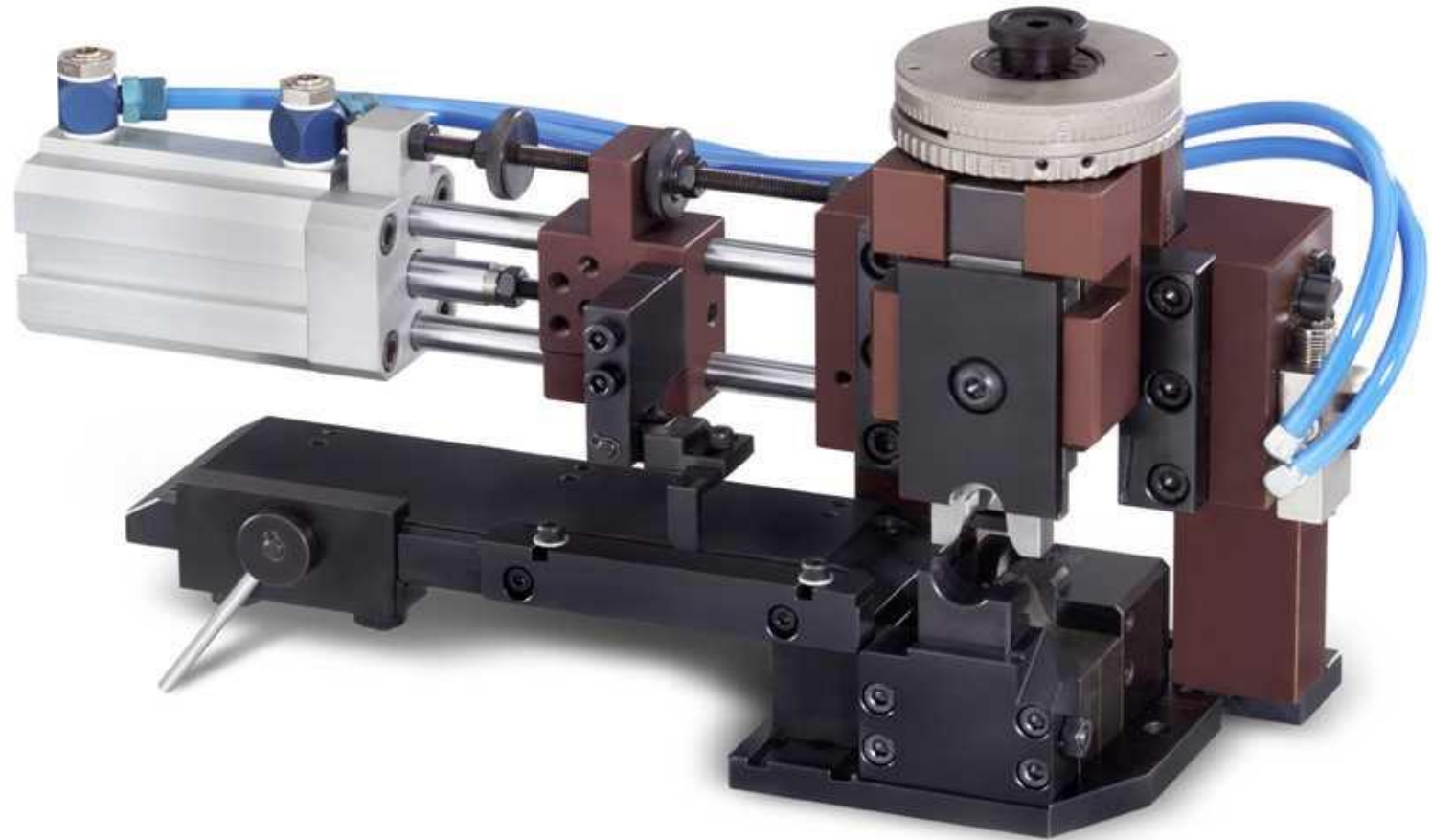

Pneumatic side feed – shut height 158.4 mm - up to 50 mm²
(depends on material thickness)

Midrange Rear Feed Applicator

POWER – CRIMP 935



Pneumatic end feed – shut height 158.4 mm - up to 50 mm²
(depends on material thickness)

More Applicators

POWER – CRIMP 938

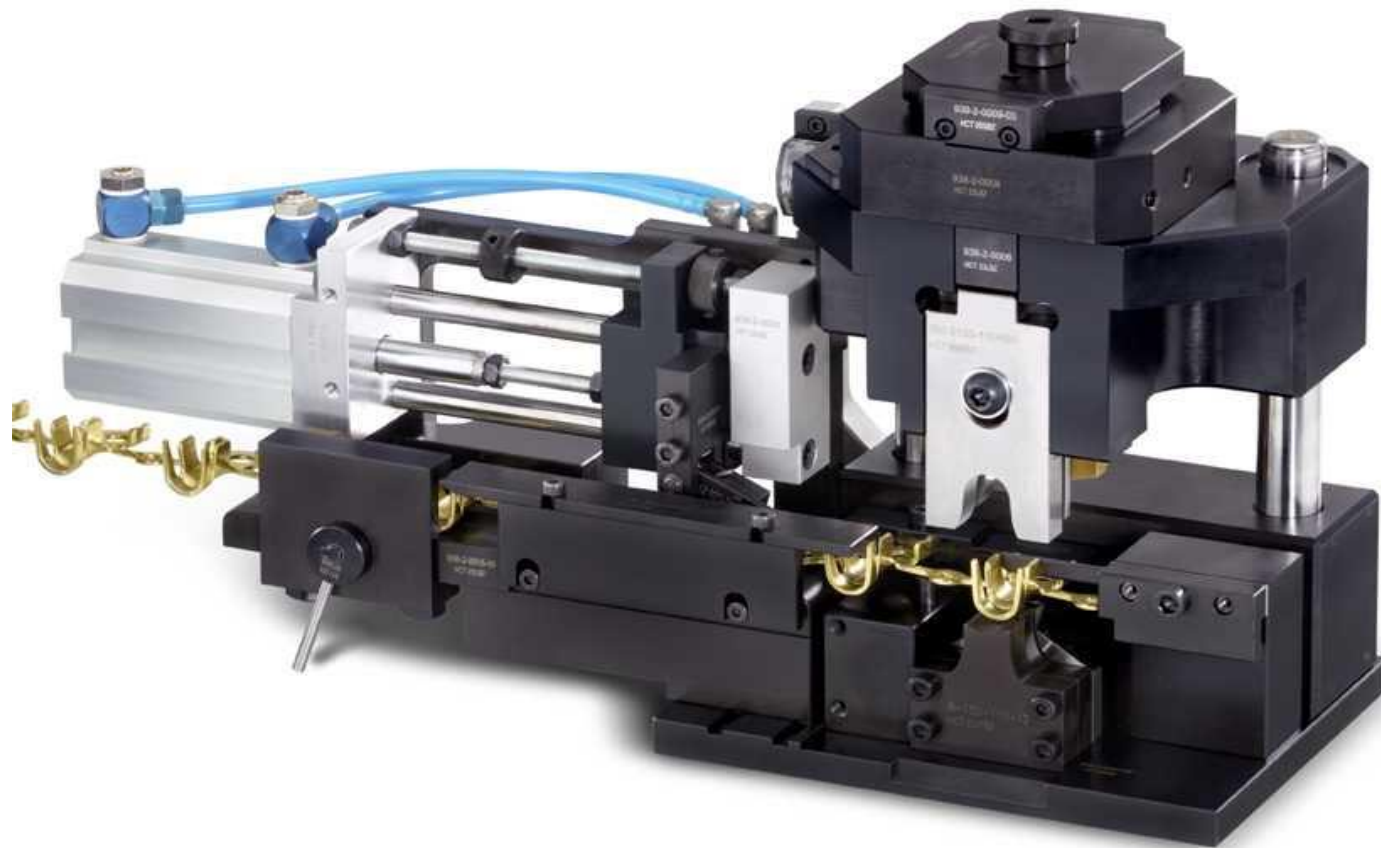

Pneumatic side feed – shut height 183 mm - 70 to 100 mm²
(depends on material thickness)

More Applicators

POWER-CRIMP 938 BK

Applicator for single terminals, f.e. forged battery terminals



Special Applicators

POWER – CRIMP 926.90

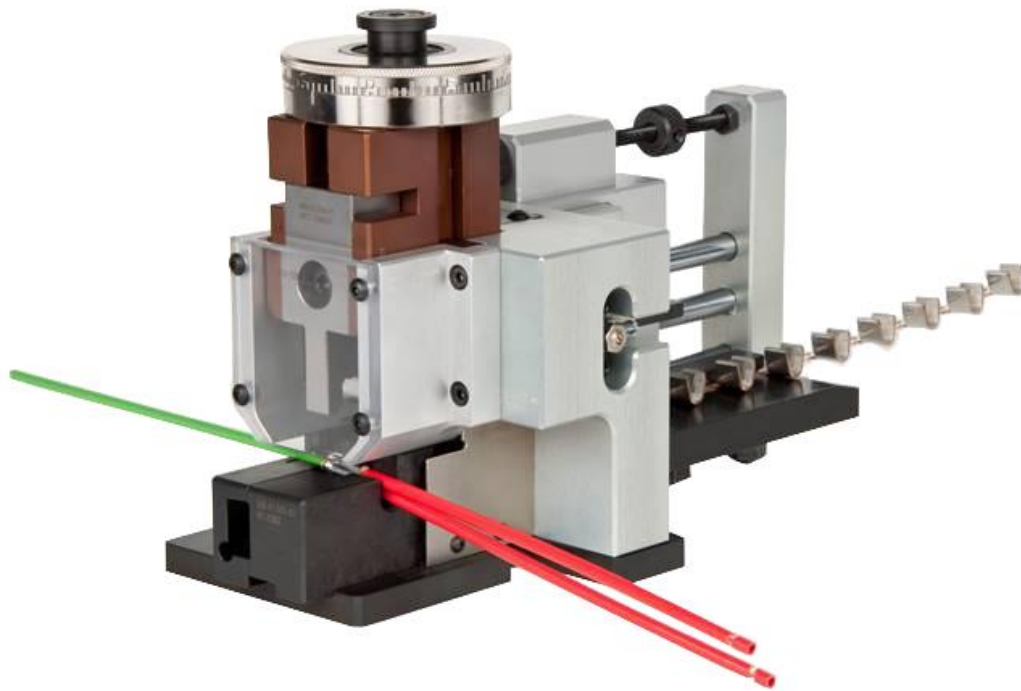

GLOBAL – STAR 951 EK



Special Applicators

POWER – CRIMP 926 ST

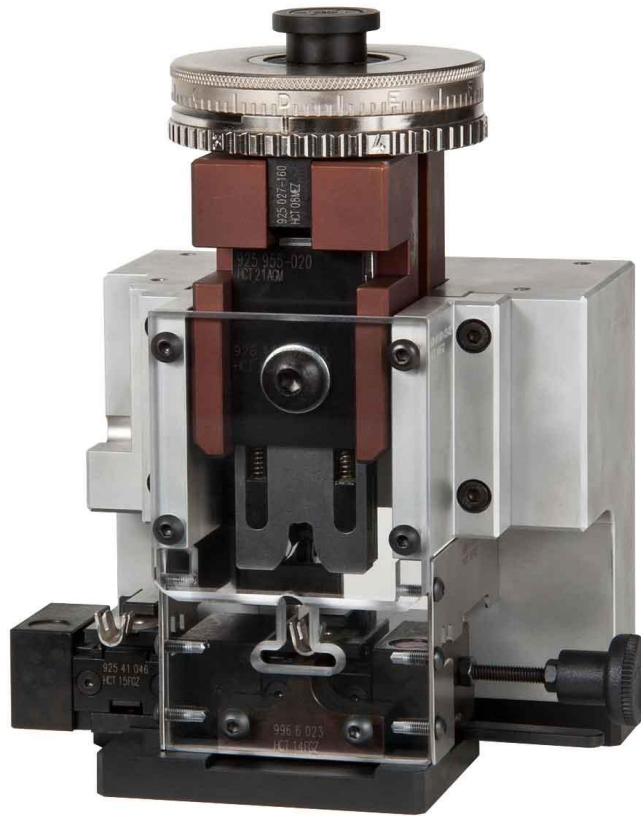

GLOBAL – STAR 952 TL

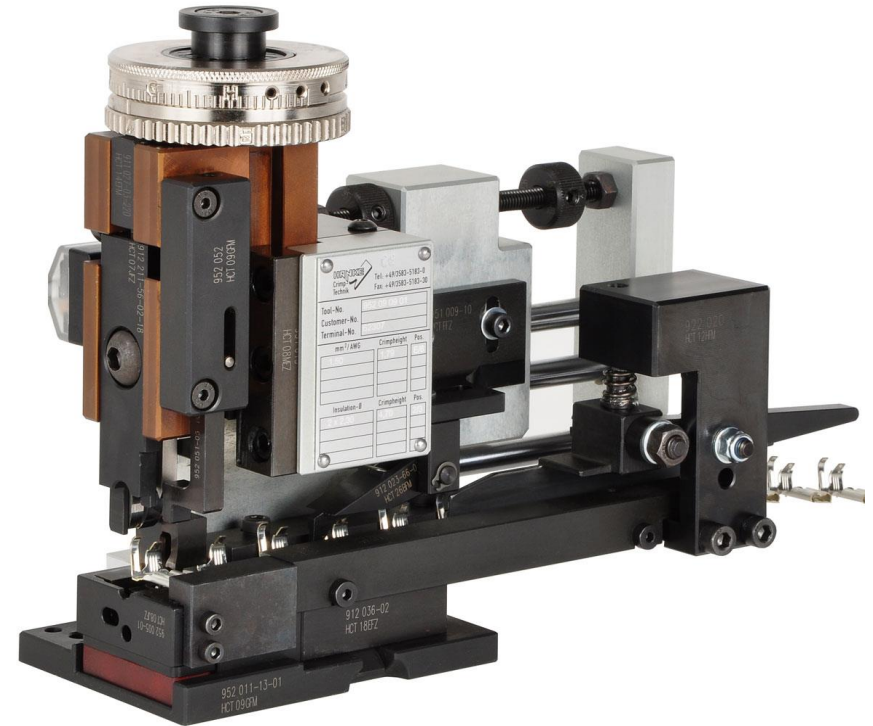

Crimp Presses

CRIMPMATIC 601

Programmable crimping machine
for Cross section up to 6 mm²



Crimp Presses

CRIMPMATIC 601 Splice

Programmable crimping machine for
Cross section up to 6 mm²
Special design for splice application



Crimp Presses

STRIPMATIC 602-20

Programmable stripper-crimper for wire cross sections up to 4 mm²



Crimp Presses

STRIPMATIC 603

Flexible stripper-crimper with different operating modes



Crimp Presses

CRIMPMATIC 970-50/60

up to 16 mm² / 20 mm² *

Crimp press built in a compact steel plate design



* depends on material thickness

Crimp Presses

CRIMPMATIC 971-150

up to 70 mm² *



CRIMPMATIC 971-220

up to 90 mm² *



* depends on material thickness

Crimp Presses

CRIMPMATIC 971-150 Battery terminal



Crimp Presses

CRIMPMATIC 972-330

- ▷ Crimp force 330 kN
- ▷ Wire cross section up to 300 mm² *
- ▷ For special applicators
f.e. steel guy for tail lift



* depends on material thickness

Special Machinery

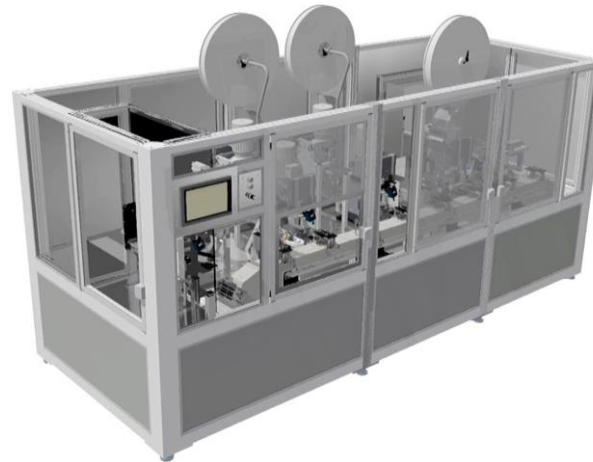

Full automatic machine for seat sensors



Placement machinery for IDC terminals

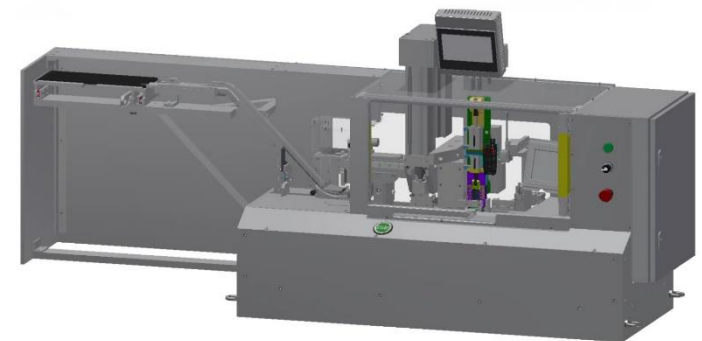

Microbridge assembling machine

Special Machinery

Semi-automatic machine for processing ribbon cable or FPC foils

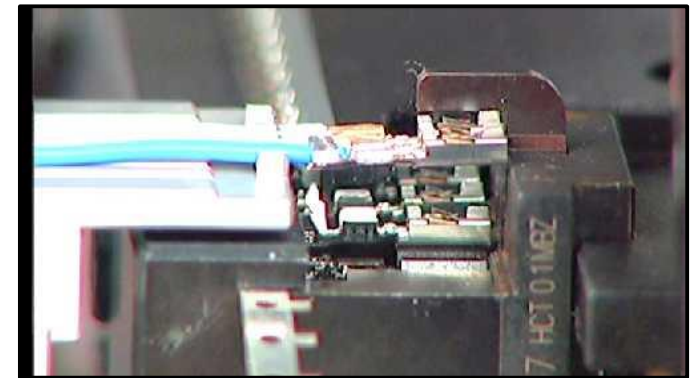
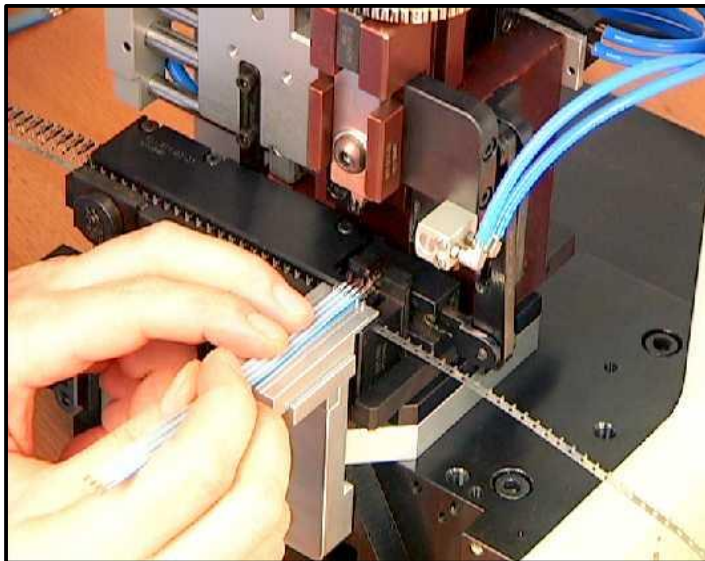

Statistics, Progress

- ▶ Applicator output
- ▶ Crimp press output
- ▶ Turnover

Applicator Output

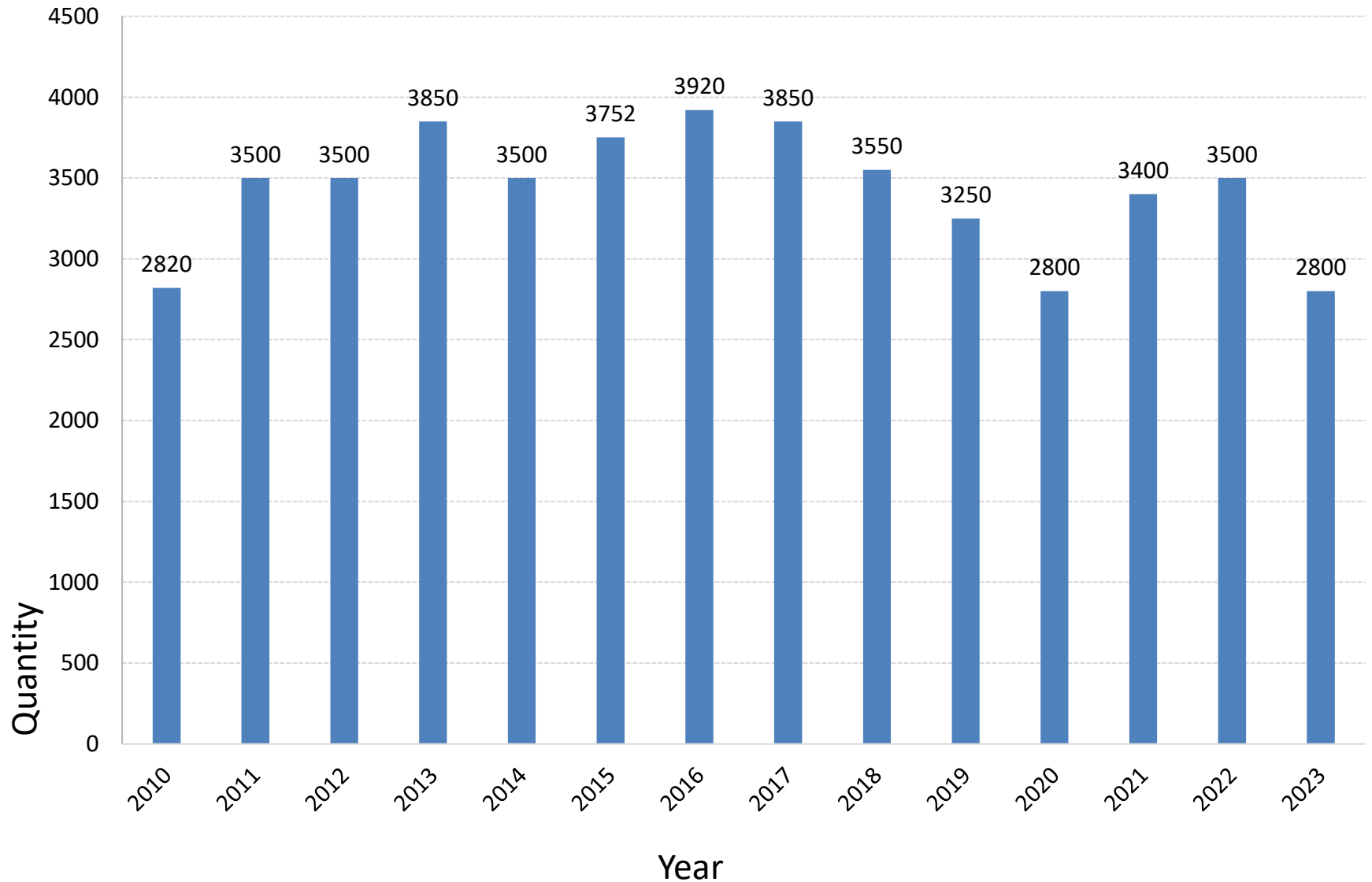

Crimp Press Output

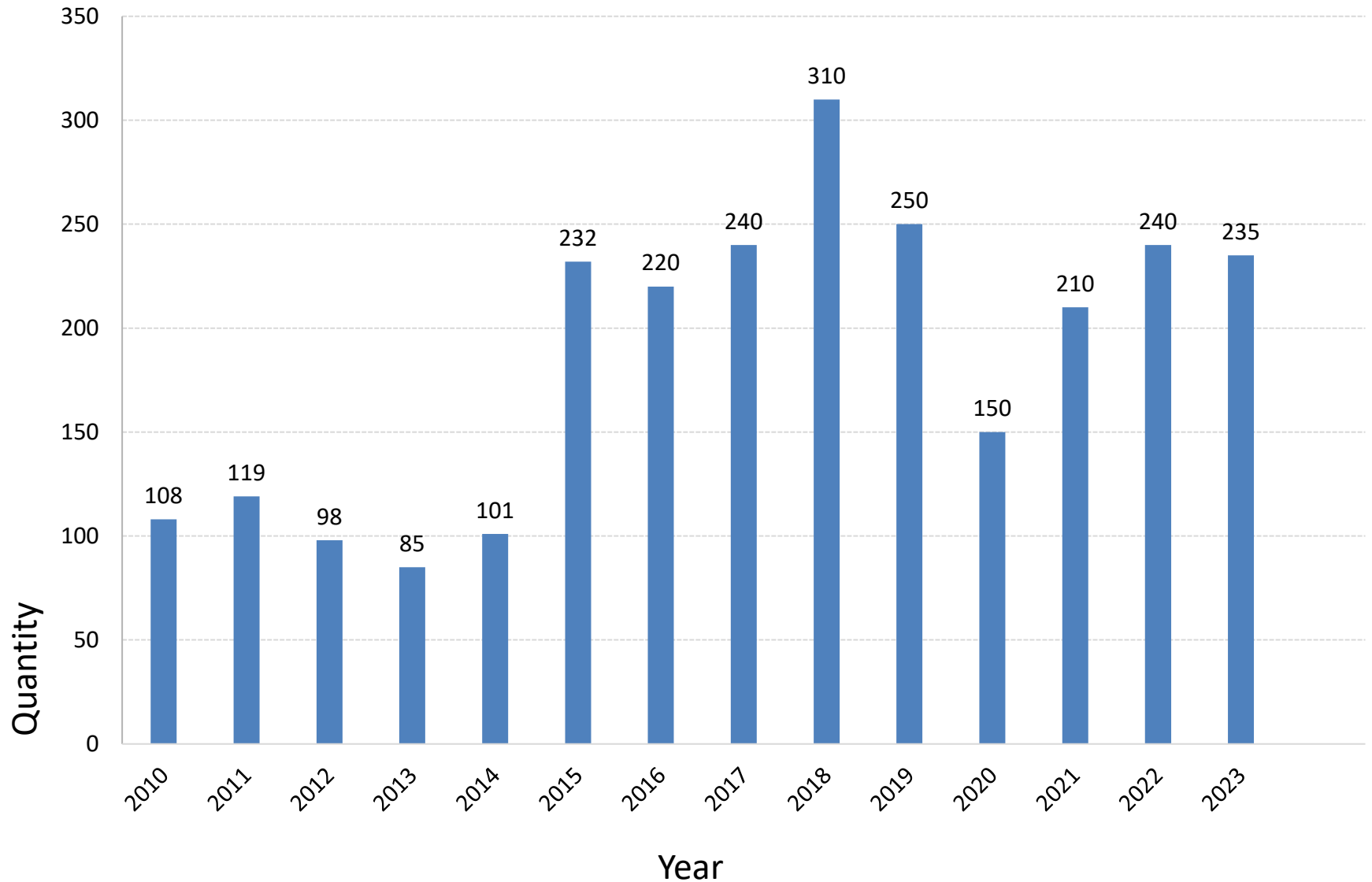

Turnover

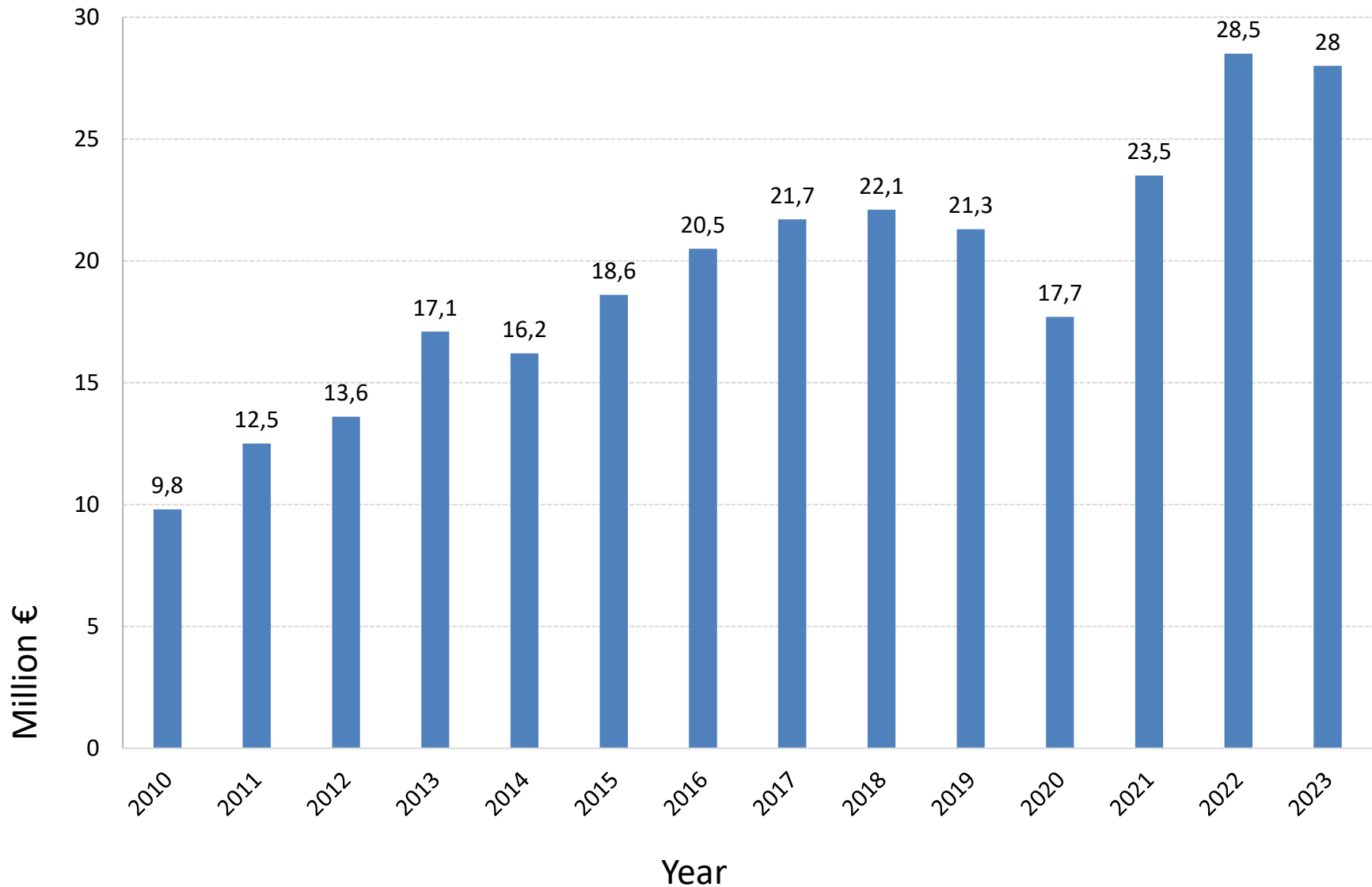

The End