

Series 70

Flexible. Tactile and reliable.

<https://eao.com/70>



70 Information about the Series

Key advantages

- Full-face illumination
- Excellent tactile feedback
- Almost limitless design possibilities
- Easy-to-clean, UV-resistant films
- PCB mount switches

Typical application areas

- Machinery
- Public transportation
- Heavy duty and special vehicles
- Marine
- Telecommunications
- Medical technology
- Energy supply
- Automation
- Building infrastructure
- Food and beverage industry

Functions

- Pushbutton
- Illuminated pushbutton
- Indicator

Design

- Flush

IP front protection

- IP40

Rating

- 42 VAC (100 mA)

Terminal

- PCB

Lens Material

- Plastic

Markings

- Printed insert film legends

Approvals

- CQC

Conformities

- CE
- UKCA
- 2011/65/EU (RoHS)



PCB	
Switching element without illumination	802
Switching element with illumination	804
Indicator element	806
Components	808
Accessories	810
Technical data	811
Application Guidelines	815

- 01
- 02
- 03
- 04
- 09
- 14
- 17
- 18
- 19
- 22
- 31
- 41
- 45
- 51
- 56
- 57
- 61
- 70**
- 71
- 82
- 84
- 92
- 96

Switching element without illumination



Product can differ from the current configuration.

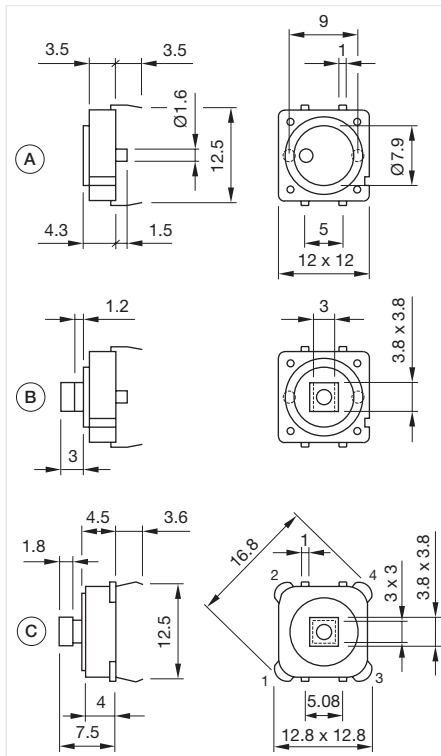

Dimensions [mm]
 A = For Part No. 70-100.0
 B = For Part No. 70-101.0
 C = For Part No. 70-201.0

Equipment consisting of (schematic overview)



Spacer cap

Page 810

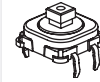

Switching element

Each Part Number listed below includes all the black components shown in the 3D-drawing.

To obtain a complete unit, please select the red components from the pages shown.

General information

- Contact normally open
- Dimensions with fitted spacing cap see details Spacing cap



Switching element

Product attributes	Contact material	Switching action	Terminal	Part No.	Wiring diagram	Component Layout
Operation without spacing cap	Silver	Momentary	PCB terminal	70-100.0	331	80



Switching element

Product attributes	Contact material	Switching action	Terminal	Part No.	Wiring diagram	Component Layout
Operation with spacing cap	Silver	Momentary	PCB terminal	70-101.0	331	80



Switching element

Product attributes	Contact material	Switching action	Terminal	Part No.	Wiring diagram	Component Layout
Operation with spacing cap	Gold	Momentary	PCB terminal	70-201.0	332	79

Wiring diagrams

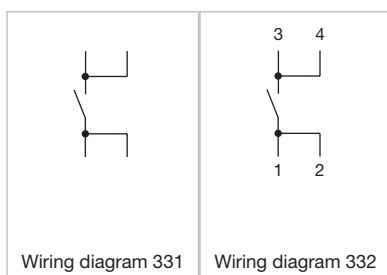

Component layouts

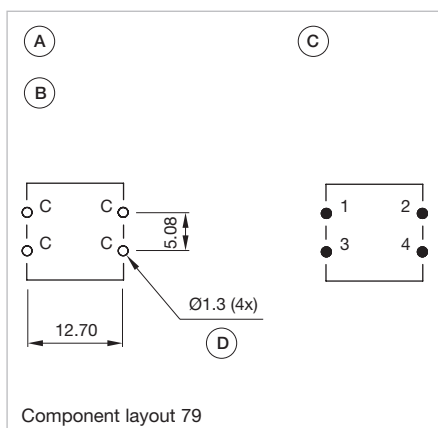

- Dimensions [mm]
 A = Switching element without illumination
 B = Drilling plan (component side)
 C = Occupancy plan (component side)
 D = Hole for switching element

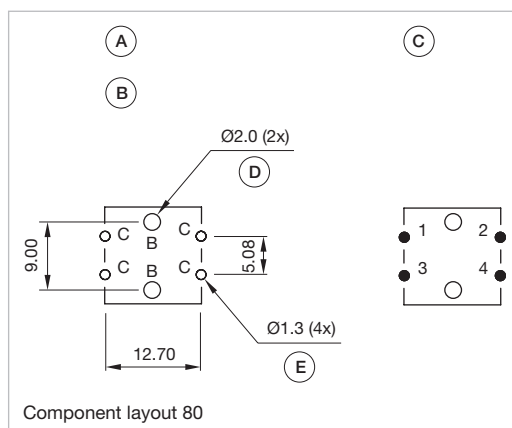

- Dimensions [mm]
 A = Switching element without illumination with
 B = Drilling plan (component side)
 C = Occupancy plan (component side)
 D = Hole for centering pins non-metallic
 E = Hole for switching element

01
02
03
04
09
14
17
18
19
22
31
41
45
51
56
57
61
70
71
82
84
92
96

Switching element with illumination



Product can differ from the current configuration.

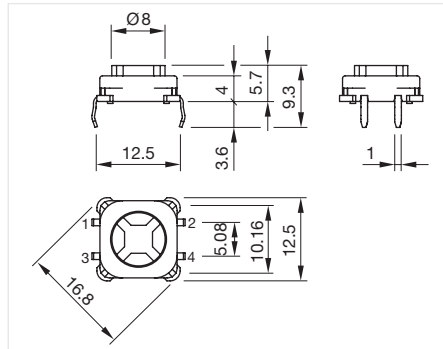

Dimensions [mm]

Equipment consisting of (schematic overview)



Lens

Page 808

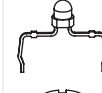

Single-LED

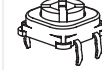

Switching element

Each Part Number listed below includes all the black components shown in the 3D-drawing.

To obtain a complete unit, please select the red components from the pages shown.

General information

- The customer has to decide what series resistor shall be used to the LED
- Luminosity and wave length variations caused by LED manufacturing processes may cause slight differences regarding the illumination. The customer has to decide what resistor shall be used to the LED
- Dimensions with fitted spacing cap see details Spacing cap
- Contact normally open



Switching element

Forward voltage	Contact material	Lumi. Intensity	Dom. Wavelength	Switching action	Terminal	Illumination colour	Part No.	Wiring diagram	Component Layout
2.0 VDC @ 20 mA	Gold	160 mcd	625 nm	Momentary	PCB terminal	Red	70-220.2S	333	82
2.9 VDC @ 20 mA	Gold	600 mcd	580 nm	Momentary	PCB terminal	Yellow	70-220.4S	333	82
3.2 VDC @ 20 mA	Gold	650 mcd	525 nm	Momentary	PCB terminal	Green	70-220.5S	333	82
3.0 VDC @ 20 mA	Gold	250 mcd	467 nm	Momentary	PCB terminal	Blue	70-220.6S	333	82
3.2 VDC @ 20 mA	Gold	500 mcd	x: 0.31 / y: 0.32 nm	Momentary	PCB terminal	White	70-220.9S	333	82



Switching element

Contact material	Switching action	Terminal	Part No.	Wiring diagram	Component Layout
Gold	Momentary	PCB terminal	92-851.342	332	82

Wiring diagrams

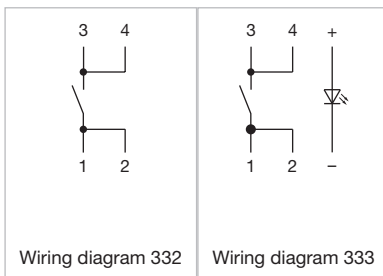

Component layouts

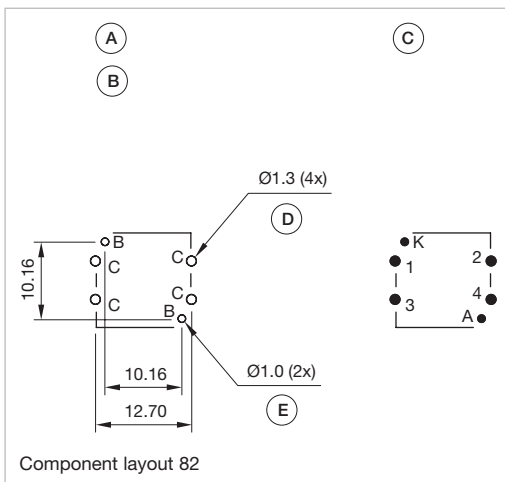

Dimensions [mm]

A = Switching element with illumination

B = Single LED

C = Drilling plan (component side)

D = Hole for switching element, Pad max. Ø 2.5 mm

E = Hole for LED

70 PCB

Indicator element



Product can differ from the current configuration.

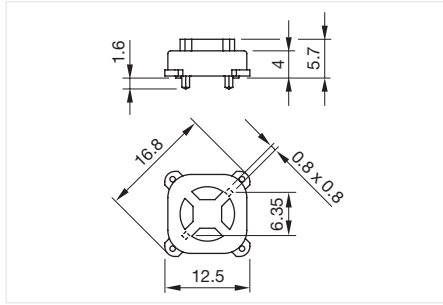

Dimensions [mm]

Equipment consisting of (schematic overview)



Lens

Page 808

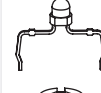

Single-LED

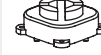

Illumination element

Each Part Number listed below includes all the black components shown in the 3D-drawing.

To obtain a complete unit, please select the red components from the pages shown.

General information

- The customer has to decide what series resistor shall be used to the LED
- Contact normally open
- Luminosity and wave length variations caused by LED manufacturing processes may cause slight differences regarding the illumination. The customer has to decide what resistor shall be used to the LED



Indicator element

Illumination colour	Forward voltage	Lumi. Intensity	Dom. Wavelength	Terminal	Part No.	Wiring diagram	Component Layout
Red	2.0 VDC @ 20 mA	160 mcd	625 nm	PCB terminal	70-820.2S	330	81
Green	3.2 VDC @ 20 mA	650 mcd	525 nm	PCB terminal	70-820.5S	330	81



Indicator element

Terminal	Part No.	Wiring diagram	Component Layout
PCB terminal	92-800.042	330	79

Wiring diagrams

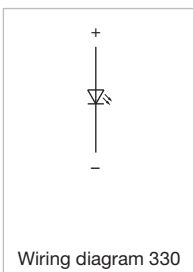

Component layouts

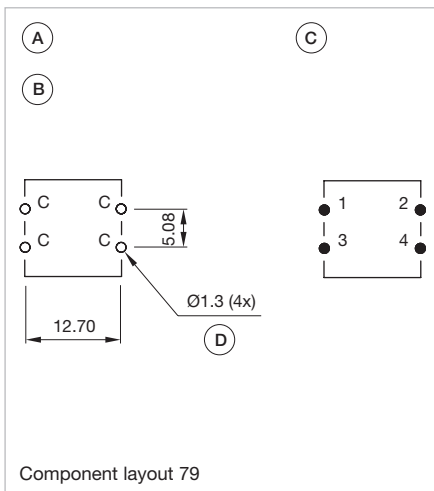

Dimensions [mm]
 A = Switching element without illumination
 B = Drilling plan (component side)
 C = Occupancy plan (component side)
 D = Hole for switching element

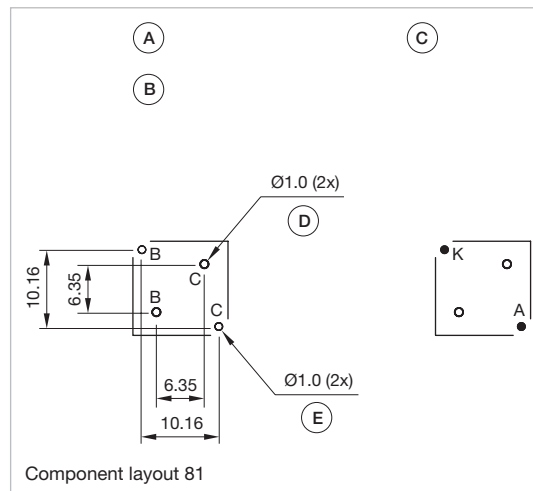

Dimensions [mm]
 A = Illumination element
 B = Single LED
 C = Drilling plan (component side)
 D = Hole for centering pins non-metallic
 E = Hole for LED



Flexible. Tactile and reliable.
EAO Series 70.

Proven in customer-specific membrane applications – thanks to almost limitless design possibilities.

- Long-standing HMI System competence
- Homogeneous illumination
- Excellent tactile feedback
- Almost limitless design possibilities
- Easy-to-clean, UV-resistant films

01
02
03
04
09
14
17
18
19
22
31
41
45
51
56
57
61
70
71
82
84
92
96

70 Components

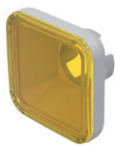

Lens plastic square

Lens material	Lens colour	Lens optics	Lens shape	Lens illumination	Dimensions	Part No.
Plastic	White	translucent	flush	illuminative	19.05 mm x 19.05 mm	70-920.9
	Red	translucent	flush	illuminative	15,4 mm x 15,4 mm	70-921.2
	Orange	translucent	flush	illuminative	15,4 mm x 15,4 mm	70-921.3
	Yellow	translucent	flush	illuminative	15,4 mm x 15,4 mm	70-921.4
	Green	translucent	flush	illuminative	15,4 mm x 15,4 mm	70-921.5
	Blue	translucent	flush	illuminative	15,4 mm x 15,4 mm	70-921.6
	White	translucent	flush	illuminative	15,4 mm x 15,4 mm	70-921.9
	Green	translucent	flush	illuminative	12,4 mm x 12,4 mm	70-922.5
	Blue	translucent	flush	illuminative	12,4 mm x 12,4 mm	70-922.6
White	translucent	flush	illuminative	12,4 mm x 12,4 mm	70-922.9	

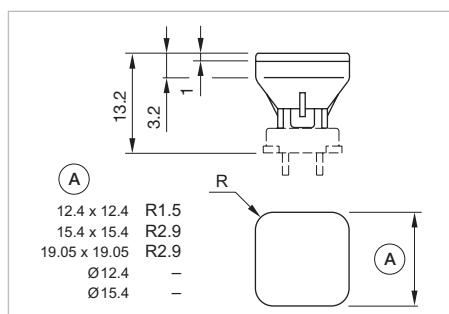

Dimensions [mm]
A = Front dimension



Lens round

Lens material	Lens colour	Lens optics	Lens shape	Lens illumination	Dimensions	Part No.
Plastic	Red	translucent	flush	illuminative	Ø 15,4 mm	70-911.2
	Orange	translucent	flush	illuminative	Ø 15,4 mm	70-911.3
	Yellow	translucent	flush	illuminative	Ø 15,4 mm	70-911.4
	Green	translucent	flush	illuminative	Ø 15,4 mm	70-911.5
	White	translucent	flush	illuminative	Ø 15,4 mm	70-911.9
	Green	translucent	flush	illuminative	Ø 12,4 mm	70-912.5
	White	translucent	flush	illuminative	Ø 12,4 mm	70-912.9

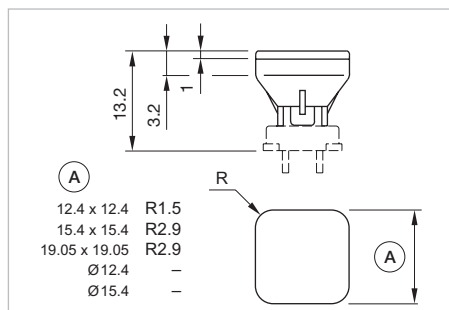

Dimensions [mm]
A = Front dimension



Single-LED, T1 3/4 MG

Illumination colour	Lumi. Intensity	Dom. Wavelength	Forward voltage	Part No.	Wiring diagram
Red	160 mcd	625 nm	2.0 VDC @ 20 mA	10-2601.3172S	70
Amber	165 mcd	605 nm	2.0 VDC @ 20 mA	10-2601.3173S	70
Yellow	600 mcd	580 nm	2.9 VDC @ 20 mA	10-2603.3174S	70
Green	650 mcd	525 nm	3.2 VDC @ 20 mA	10-2603.3175S	70
Blue	250 mcd	467 nm	3.0 VDC @ 20 mA	10-2603.3176S	70
White	500 mcd	x: 0.31 / y: 0.32 nm	3.2 VDC @ 20 mA	10-2603.3178S	70

Additional information

- The customer has to decide what series resistor shall be used to the LED
- Luminosity and wave length variations caused by LED manufacturing processes may cause slight differences regarding the illumination. The customer has to decide what resistor shall be used to the LED

Wiring diagrams

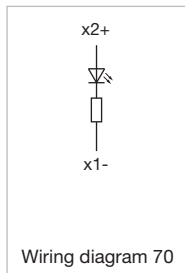

70 Accessories

Front side



Spacing cap

Product attributes	Dimensions	Part No.
Without recesses for LED	18.9 mm	70-901.0
2 recesses for LED	9 mm	70-910.0
	13 mm	70-911.0
	22.5 mm	70-912.0

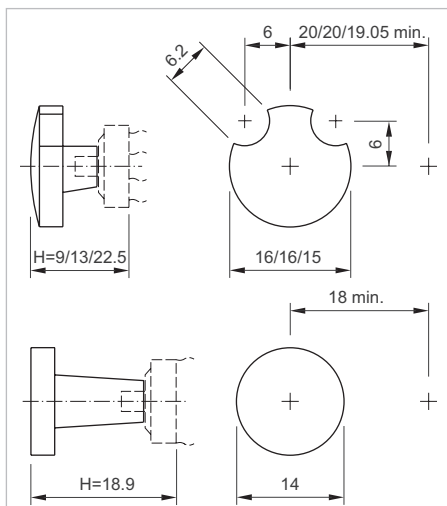

Dimensions [mm]

Switching element illuminated Part No. 92-851.342

Switching system

Short-travel switching system with two independent contact points and tactile operation. Guarantees reliable switching even of very light loads 1 normally open contact

Material

Material of contact
Gold-plated silver

Switching element
Plastic

Mechanical characteristics

Actuating force
With overlay foil 4 N \pm 0.2 N
Max. actuating force >50 N, as per DIN 42115

Actuating travel
Approx. 0.5 mm

Resistance to heat of soldering
250 °C, 3 s (PCB assembly)
320 °C, 3 s (when using a soldering iron)

Mechanical lifetime
 \geq 5 Mio. operations (switching element without overlay)
 \geq 1 Mio. operations (switching element under overlay)

Protection
IP40 (only switching element)
IP65 front side with overlay foil

Electrical characteristics

Electrical life
 \geq 500 000 cycles of operation at 42 VDC, 50 mA, as per IEC 60512-5-9c
When attention is paid to the direction of current flow from terminal 3/4 to 1/2 the electrical life can be prolonged.

Switching voltage and switching current
Switching voltage min. 50 mV AC/DC
max. 42 V AC/DC
Switching current min. 10 μ A AC/DC
max. 100 mA AC/DC
Power rating max. 2 W

Electric strength
500 VAC, 50 Hz, 1 minute, as per IEC 60512-2-4a

Ambient conditions

Storage temperature
-40 °C ... +85 °C

Operating temperature
-25 °C ... +70 °C

Approvals

Approbations
CQC

Conformities
CE
UKCA
2011/65/EC (RoHS)

- 01
- 02
- 03
- 04
- 09
- 14
- 17
- 18
- 19
- 22
- 31
- 41
- 45
- 51
- 56
- 57
- 61
- 70
- 71
- 82
- 84
- 92
- 96

70 Technical data

Switching element non-illuminated Part No. 70-100.0 and 70-101.0

Switching system

Short-travel switching system with two independent contact points and tactile operation. Guarantees reliable switching even of very light loads 1 normally open contact

Material

Material of contact
Silver (Ag)

Mechanical characteristics

Actuating force
With overlay foil 5 N \pm 2 N
Max. actuating force > 50 N, as per DIN 42115

Actuating travel
0.3 mm

Mechanical lifetime
500 000 operations with overlay

Protection
IP65 front side with overlay foil

Electrical characteristics

Electrical life
at 5 VDC, 1 mA 500 000 cycles of operation

Switching voltage and switching current
Max. 12 VDC, 50 mA
Min. 1 VDC, 10 mA

Electric strength
250 VAC for 1 minute

Ambient conditions

Storage temperature
-30 °C ... +85 °C

Operating temperature
-20 °C ... +70 °C

Approvals

Approbations
CQC

Conformities
CE
UKCA

Switching element non-illuminated Part No. 70-201.0

Switching system

Short-travel switching system with two independent contact points and tactile operation. Guarantees reliable switching even of very light loads 1 normally open contact

Material

Material of contact
Gold-plated silver

Switching element
Plastic

Mechanical characteristics

Actuating force
With overlay foil 2.1 N ± 0.2 N
Max. actuating force > 50 N, as per DIN 42115

Actuating travel
Approx. 0.5 mm

Resistance to heat of soldering
260 °C, 3 s, as per IEC 60068-2-20

Mechanical lifetime
≥ 5 Mio. cycles of operation (switching element without overlay)
≥ 1 Mio. cycles of operation (switching element under overlay)

Protection
IP40 (only switching element)
IP65 front side with overlay foil

Electrical characteristics

Electrical life
≥ 500 000 cycles of operation at 42 VDC, 50 mA, as per IEC 60512-5-9c
When attention is paid to the direction of current flow from terminal ¾ to ½ the electrical life can be prolonged.

Switching voltage and switching current
Switching voltage min. 50 mV AC/DC
max. 42 V AC/DC
Switching current min. 10 µA AC/DC
max. 100 mA AC/DC
Power rating max. 2 W

Electric strength
500 VAC, 50 Hz, 1 minute, as per IEC 60512-2-4a

Ambient conditions

Storage temperature
-40 °C ... + 85 °C

Operating temperature
-25 °C ... + 70 °C

Approvals

Approbations
CQC

Conformities
CE
UKCA
2011/65/EC (RoHS)

70 Application Guidelines

Suppressor circuits

When switching inductive loads such as relays, DC motors, and DC solenoids, it is always important to absorb surges (e.g. with a diode) to protect the contacts. When these inductive loads are switched off, a counter emf can severely damage switch contacts and greatly shorten lifetime.

Fig. 1 shows an inductive load with a free-wheeling diode connected in parallel. This free-wheeling diode provides a path for the inductor current to flow when the current is interrupted by the switch. Without this free-wheeling diode, the voltage across the coil will be limited only by dielectric breakdown voltages of the circuit or parasitic elements of the coil. This voltage can be kilo-

volts in amplitude even when nominal circuit voltages are low (e.g. 12 VDC) see Fig. 2.

The free-wheeling diode should be chosen so that the reverse breakdown voltage is greater than the voltage driving the inductive load. The DC blocking voltage (VR) of the free-wheeling diode can be found in the datasheet of a diode. The forward current should be equal or greater than the maximum current flowing through the load.

To get an efficient protection, the free-wheeling diode must be connected as close as possible to the inductive load!

Switching with inductive load
Fig. 1

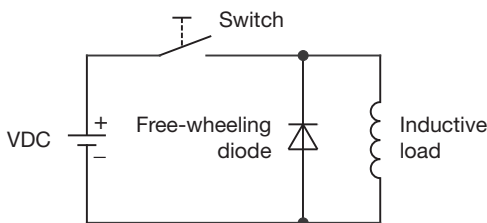

Counter EMF
over load without free-wheeling diode
Fig. 2

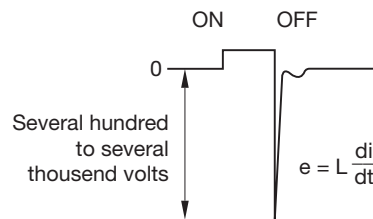

Note for soldering

Process parameter for wave soldering
Basic specification for wave soldering J-STD 75 W4C.

Maximum temperature on the component side (Temp 2): (Temperature must not exceed during the entire processing)	120 °C
Preheating phase (t1 ... t2): Ramp up:	70 ... 120 sec typ. +1 °C/sec
Ramp up to maximum temperature (t2 ... t3):	not defined
Maximum temperature on the soldering side (Temp 3): Maximum time of soldering process (t3 ... t4):	250 °C 3 sec
Ramp down at 170 °C:	typ. -2 °C/sec

Temperature curve wave soldering

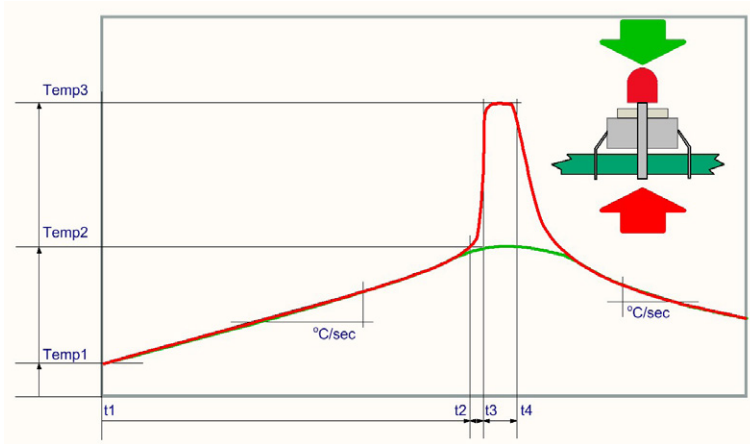

Green curve: Temperature on the component side of the pcb
 Red curve: Temperature on the soldering side of the pcb

Room temperature: Temp 1

Preheating: Temperature process = Temp 1 ... Temp 2
 Process time = t1 ... t2

Ramp up to soldering temperature: Process time = t2 ... t3

Soldering phase: Temperature process = Temp 3
 Process time = t3 ... t4

Iron soldering

Basic specification for iron soldering IEC 60068-2-20

Maximum temperature at tip of iron: 320 °C
 Maximum soldering time: 3 sec

Cleaning/Lacquering

The switching elements are not sealed. Cleaning up the PCB may damage the contacts in the switching elements. For this reason, the following points should be noted:

- When soldering make sure that the flux does not pass on the upper side of the PCB.
- When cleaning the PCB with detergents ensure that no dust or other debris may get inside of the switching elements.
- Ensure that no lacquer penetrates into the interior of the switching element when lacquering the PCB.

Storage of components

To obtain the optimum solderability of the components, the following points should be noted during storage:

- Do not store components in locations with high temperature or humidity.
- Do not expose components to corrosive gases.
- Avoid direct sunlight for a long period.

