



KTS COMFORT

Tape dispenser

KTS 50/100/160 COMFORT

Convenient tape dispenser

Flexible handling – high quality:

The KTS Comfort series is the ideal tape dispenser for almost all types of tape. Its strength lies in its ability to process various different tapes. The KTS Comfort machines can reliably dispense all types of tapes, including thick or strong adhesive tapes which require strong pull-off forces. The three different tape types saved in the standard version – easy, normal or hard to pull-off – can be individually set and saved. Each program can be quickly accessed when the tape is changed.

With regard to tape lengths, the KTS Comfort series offers outstanding flexibility and user friendliness: Up to 12 different sequences with customized tape lengths can be saved. The programmable tape length is between 30 and 9,999 millimeters. Once the tape has been pulled off, the machine delivers a sequential output of the relevant tape lengths. This makes the KTS 50 Comfort particularly suitable for fastening wire harnesses to the roof or in the vehicle body. This machine can also be used for spot taping wire harnesses by hand: This allows the sequential processing of items with different cross sections and ensures that the optimum tape length is always dispensed.

An excellent feature of the KTS Comfort series is the quality of the blades used. These have been specifically developed by Komax for the processing of tape. Komax pays particular attention to the finishing of blades in its own factory. The result is an excellent cutting quality, evident in the daily handling of the machine.



KTS 50 COMFORT

HIGH-PERFORMANCE TAPE DISPENSER

THE HIGH-QUALITY CUTTING UNIT FOR
PROCESSING VARIOUS TYPES OF TAPE



◀ The KTS Comfort series processes virtually all types of tape.
Extra service: Upon customer request, KABATEC can carry out a feasibility check using tape samples.

MORE FLEXIBILITY IN PRODUCTION

TAPE DISPENSE SPEED AND
TAPE LENGTH CAN BE ADJUSTED –
INDIVIDUALLY AND EASILY

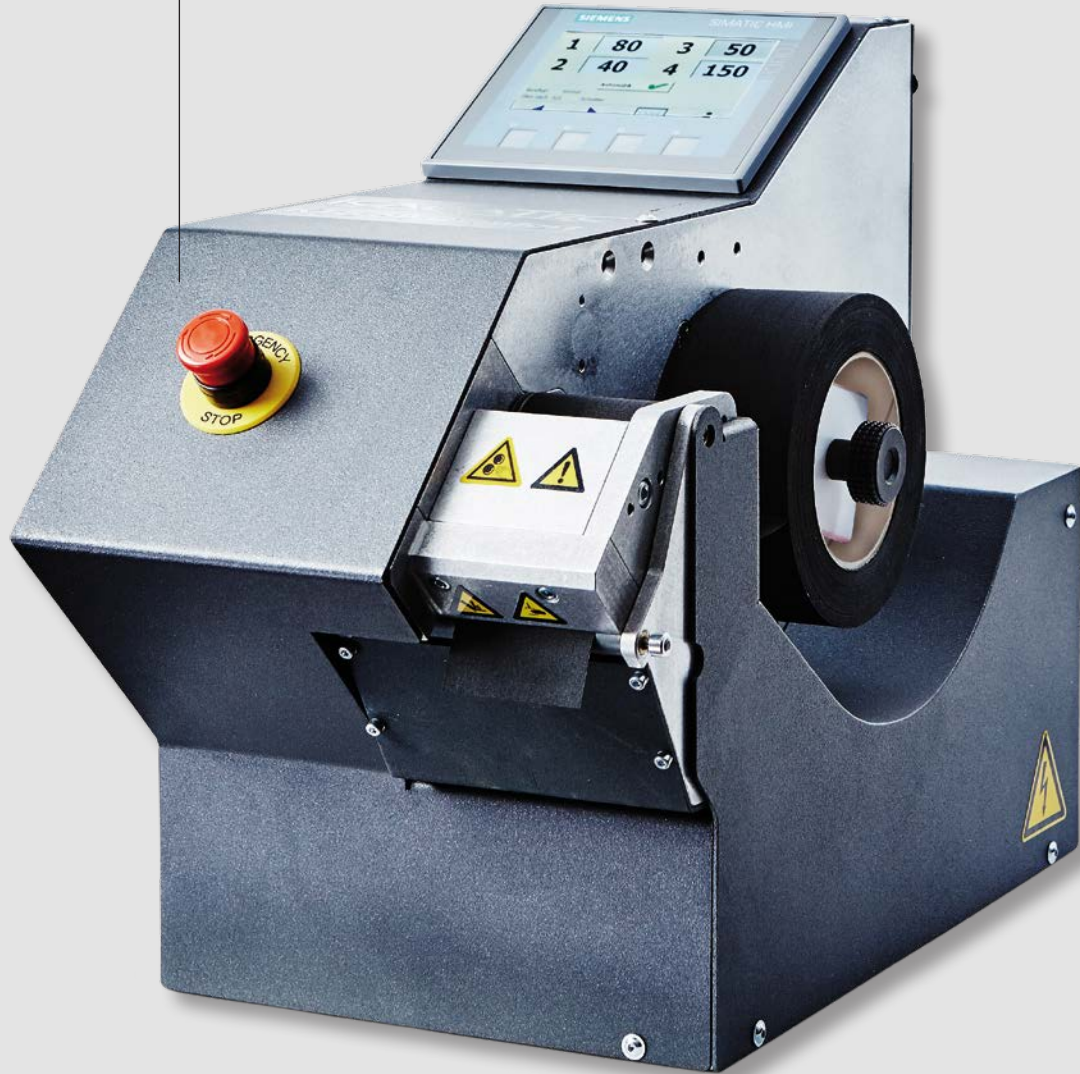

KTS 160 Comfort with sleeve tape

The perfect solution for maximum wire harness flexibility: Alongside conventional tapes with a maximum width of 160 millimeters, the KTS 160 Comfort can also process sleeve tapes.

This special type of tape design reduces the contact of the adhesive with the wire harness. This helps the wire harness retain its flexibility and elasticity.

- The amount of tape required is precisely calculated since the number of tape windings can be programmed.
- Up to 80 percent reduction in material costs.

High flexibility for individual working

- Three speed levels: Motor speeds can be individually adapted to the different types of tape.
- The machine has two different operating modes: Sequential mode and step-by-step mode.
- Up to 12 different tape lengths are saved.

Robust – reliable – tried-and-tested

- The tape dispenser guarantees a consistent process and reproducible quality in accordance with the highest specifications.
- Superior quality by using high-quality and tried-and-tested components, robust and low-maintenance “Made in Burghaun” chopping blades.
- The KTS Comfort series is one of Komax’s most successful models which have established themselves on the international market.

User-friendly and low maintenance

- The required tape length can be easily entered on the touch panel.
- Maintenance and oiling intervals are displayed automatically on the touch panel.

01

Use in the automotive industry:
The KTS 50 Comfort is the right choice for processing special-purpose tapes, for example for roof linings.

02

Fast manufacturing – optimized tape consumption: Up to 12 different lengths can be programmed.

03

The KTS Comfort has three speed levels. On the one hand, it can deliver more pull-off force for heavy, industrial tapes but can also be used for efficiently processing fragile tapes thanks to its individual setting mode.

04

Manual mode enables the user dispense tape in the preset length.

05

Sharpest blade quality:
Komax focuses on high level of vertical integration.



01



02



03



04



05

Precise solutions for special tape types:
On customer request, Komax can deliver a wide range of practical options for the KTS Comfort series.

**Option exclusively for KTS 50 Comfort:
pull-off device for liners**

A liner rewinder, specifically designed for processing tape with liner, is available for the KTS 50 Comfort model. This optional device winds up the liner during dispensing. Consistent winding is ensured because the device is connected directly to the conveyor rollers. Tape rollers with large outer diameters can also be easily used with this device. Another benefit is the flanged wheel with quick-action lock which enables the roller to be changed without requiring any tools.



Options for all models of the KTS Comfort series:

**No gluing:
air nozzle**

Thin and lightweight tapes flap back quickly. To prevent this from happening, an air nozzle can be fitted as an option which emits a blast of air to stabilize the tape. This offers a clear handling benefit because it stops the tape from sticking together and the tape can be removed more easily. Clever detail: The level of the air blast can be reduced or increased with a throttle. It releases a blast of air to stabilize the tape (see the arrows in the image below).

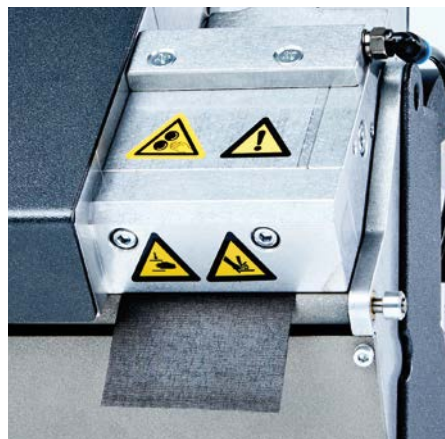

**Precise processing of special-
purpose tapes: press-on roller**

An additional press-on roller can be installed for PVC tapes with high pull-off forces. It presses the tape against the pre-feed roller and therefore ensures optimum processing.

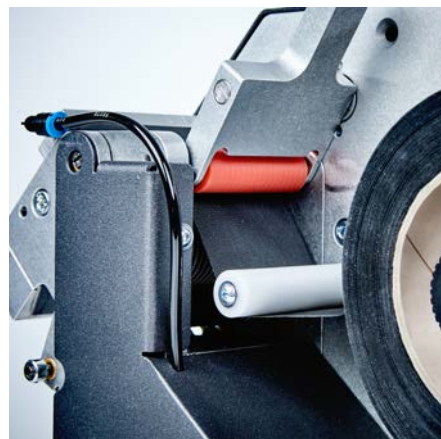

**Always perfectly oiled:
manual oiling device**

The oil consumption varies depending on the tape used. The manual oiling device is recommended for non-woven tapes and thick fabric tapes to ensure a constantly high quality of cutting. Adhesive does not stick to the blade. The cycle time of the oiling operations can also be set individually to prevent residues sticking to the tape as a result of oiling too frequently.

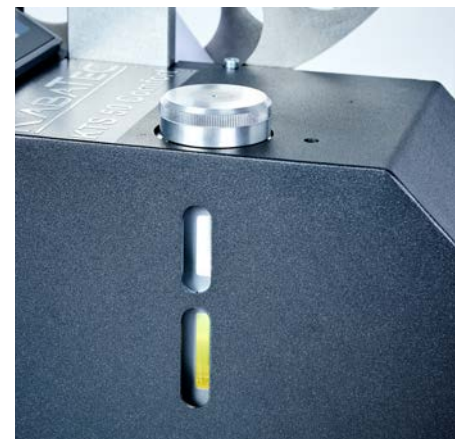

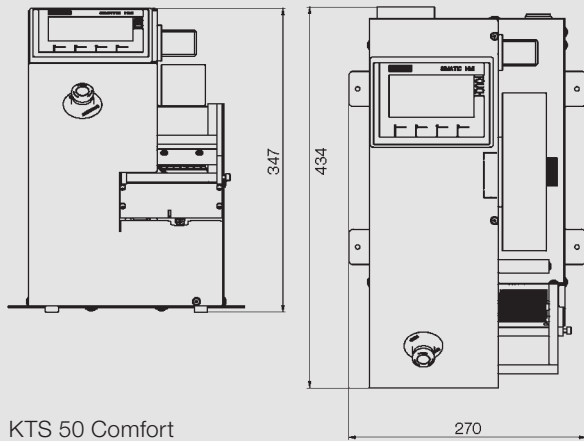

KTS 50 Comfort

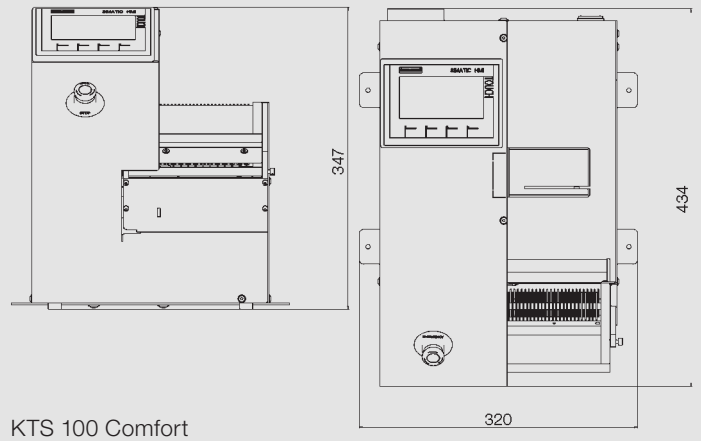

KTS 100 Comfort

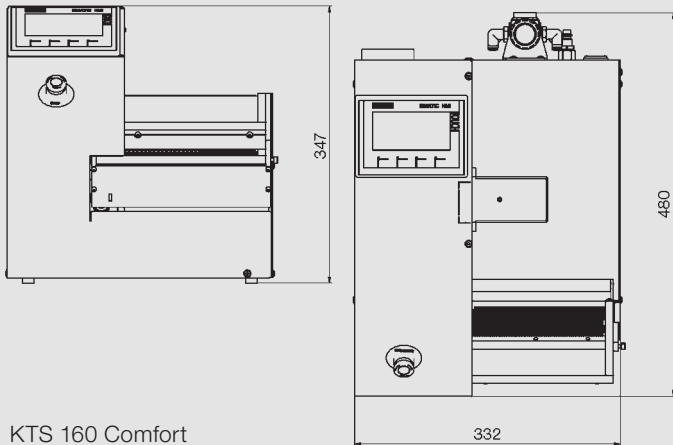

KTS 160 Comfort

Technical data - the KTS Comfort at a glance

Application	Dispensing and supply of different types and lengths of tape segments
Adhesive tape	
Dispensing length	30 – 9.999 mm
Cutting angle for conveyor direction	± 5%
Adhesive tape materials	A range of automotive and industrial tapes
Tape width	KTS 50 comfort: 9 – 50 mm KTS 100 comfort: 19 – 100 mm KTS 160 comfort: 30 – 160 mm
Tape roller core diameter (standard)	1.5" and 3"
Maximum tape roller outer diameter	max. 180 mm
Machine data	
Electric connection	L/N/PE 100 – 240V AC/50 – 60Hz +-10%
Pre-fuse	10 A
Connected load	700 W
Control voltage	24 V DC
Operating pressure	6 bar (0.6 MPa / 87 psi)
Dimensions (H/W/D)	KTS 50 comfort: 347 mm x 270 mm x 434 mm KTS 100 comfort: 347 mm x 320 mm x 434 mm KTS 160 comfort: 347 mm x 332 mm x 480 mm

Komax – leading the field now and in the future

As a pioneer and market leader in the field of automated wire processing, Komax provides its customers with innovative and sustainable solutions for any situation that calls for precise contact connections. Komax manufactures series and customer-specific machinery for various industries, catering to every degree of automation and customization. Its range of quality tools, test systems, and intelligent networking solutions complete the portfolio, and ensure safe and efficient production. Komax is a globally active Swiss company with development and production facilities on several continents. Komax uses its extensive distribution and service network, which includes local companies and their employees, to support customers across the world on site, thus ensuring the availability and value of their investments after equipment commissioning through standardized service processes.

Illustrations and descriptions contain additional equipment. Subject to changes as a result of technical development.

Komax Taping GmbH & Co. KG
Am Grubener Weg 15
D-36151 Burghaun
Phone +49 6652 79362-0
sales.bgh@komaxgroup.com

komax
komaxgroup.com